

EVA-M8M

u-blox M8 concurrent GNSS modules

Hardware Integration Manual

Abstract

This document describes the hardware features and specifications of the cost effective EVA-M8M concurrent GNSS modules featuring the u-blox M8 positioning engine.

The EVA-M8M series boasts the industry's smallest form factor and is a fully tested standalone solution that requires no host integration.

The EVA-M8M modules combine exceptional GNSS performance with highly flexible power, design, and serial communication options.



www.u-blox.com

UBX-14006179 - R02

Document Information

Title	EVA-M8M		
Subtitle	u-blox M8 concurrent GNSS modules		
Document type	Hardware Integration Manual		
Document number	UBX-14006179		
Revision and date	R02	09-Dec-2014	
Document status	Early Production Information		

Document status explanation

Objective Specification	Document contains target values. Revised and supplementary data will be published later.		
Advance Information	Document contains data based on early testing. Revised and supplementary data will be published later.		
Early Production Information	Document contains data from product verification. Revised and supplementary data may be published later.		
Production Information	Document contains the final product specification.		

This document applies to the following products:

Product name	Type number	ROM/FLASH version	PCN reference
EVA-M8M	EVA-M8M-0-00	ROM 2.01 / Flash FW 2.01	N/A
EVA-M8M	EVA-M8M-1-00	ROM 2.01 / Flash FW 2.01	N/A

u-blox reserves all rights to this document and the information contained herein. Products, names, logos and designs described herein may in whole or in part be subject to intellectual property rights. Reproduction, use, modification or disclosure to third parties of this document or any part thereof without the express permission of u-blox is strictly prohibited.

The information contained herein is provided "as is" and u-blox assumes no liability for the use of the information. No warranty, either express or implied, is given, including but not limited, with respect to the accuracy, correctness, reliability and fitness for a particular purpose of the information. This document may be revised by u-blox at any time. For most recent documents, please visit www.u-blox.com.

Copyright © 2014, u-blox AG

u-blox® is a registered trademark of u-blox Holding AG in the EU and other countries. ARM® is the registered trademark of ARM Limited in the EU and other countries.

Preface

u-blox Technical Documentation

As part of our commitment to customer support, u-blox maintains an extensive volume of technical documentation for our products. In addition to our product-specific technical data sheets, the following manuals are available to assist u-blox customers in product design and development.

- **GPS Compendium:** This document, also known as the GPS book, provides a wealth of information regarding generic questions about GPS system functionalities and technology.
- **Receiver Description including Protocol Specification:** This document describes messages, configuration and functionalities of the EVA-M8M software releases and receivers.
- **Hardware Integration Manuals:** These manuals provide hardware design instructions and information on how to set up production and final product tests.
- **Application Notes:** These documents provide general design instructions and information that applies to all u-blox GNSS positioning modules.

How to use this Manual

This manual has a modular structure. It is not necessary to read it from beginning to end.

The following symbols highlight important information within the manual:



An index finger points out key information pertaining to module integration and performance.



A warning symbol indicates actions that could negatively influence or damage the module.

Questions

If you have any questions about EVA-M8M integration, please:

- Read this manual carefully.
- Contact our information service on the homepage <http://www.u-blox.com>.
- Read the questions and answers on our FAQ database on the homepage.

Technical Support

Worldwide Web

Our website (<http://www.u-blox.com>) is a rich pool of information. Product information, technical documents and helpful FAQ can be accessed 24 h a day.

By E-mail

If you have technical problems or cannot find the required information in the provided documents, contact the closest Technical Support office. To ensure that we process your request as soon as possible, use our service pool email addresses rather than personal staff email addresses. Contact details are at the end of the document.

Helpful Information when Contacting Technical Support

When contacting Technical Support please have the following information ready:

- Receiver type (e.g. NEO-7N-0-000), Datacode (e.g. 172100.0100.000) and firmware version (e.g. ROM1.0)
- Receiver/module configuration
- Clear description of your question or the problem (may include a u-center logfile)
- A short description of the application
- Your complete contact details

Contents

Preface	3
Contents.....	4
1 Hardware description	7
1.1 Overview	7
2 Design-in.....	8
2.1 Power management	8
2.1.1 Overview	8
2.1.2 Power management configuration	9
2.2 Interfaces.....	10
2.2.1 UART interface	10
2.2.2 Display Data Channel (DDC) Interface	10
2.2.3 SPI Interface	11
2.2.4 USB interface.....	11
2.2.5 SQI Flash memory.....	12
2.3 I/O Pins	13
2.3.1 Time pulse.....	13
2.3.2 External interrupt	13
2.3.3 Active antenna supervisor.....	13
2.3.4 Electromagnetic interference on I/O lines.....	14
2.4 Real-Time Clock (RTC)	14
2.4.1 RTC using a crystal	15
2.4.2 RTC derived from the system clock	15
2.4.3 RTC using an external clock.....	15
2.4.4 Time aiding	15
2.5 RF input.....	16
2.5.1 Active Antenna.....	16
2.5.2 Passive Antenna	16
2.5.3 Improved Jamming Immunity	16
2.6 Safe Boot Mode (SAFEBOOT_N pin).....	17
2.7 RESET_N.....	17
2.8 Design-in checklist.....	18
2.8.1 General considerations	18
2.8.2 Schematic design-in for EVA-M8M.....	18
2.9 Pin description	19
2.10 Layout design-in checklist	20
2.11 Layout.....	20
2.11.1 Footprint	21
2.11.2 Paste mask	21

2.11.3	Placement	22
2.12	Migration considerations.....	22
2.12.1	C88-M8M - Evaluating EVA-M8M on existing NEO-xM sockets	22
2.13	EOS/ESD/EMI precautions.....	24
2.13.1	Electrostatic Discharge (ESD).....	24
2.13.2	ESD protection measures.....	24
2.13.3	Electrical Overstress (EOS).....	24
2.13.4	EOS protection measures.....	25
2.13.5	Applications with cellular modules	25
3	Product handling & soldering.....	27
3.1	Packaging, shipping, storage and moisture preconditioning	27
3.2	ESD handling precautions.....	27
3.3	Soldering	27
3.3.1	Soldering paste.....	27
3.3.2	Reflow soldering	28
3.3.3	Optical inspection.....	28
3.3.4	Repeated reflow soldering.....	28
3.3.5	Wave soldering.....	28
3.3.6	Rework.....	28
3.3.7	Conformal coating	28
3.3.8	Casting.....	28
3.3.9	Use of ultrasonic processes.....	28
4	Product testing	29
4.1	Test parameters for OEM manufacturer.....	29
4.2	System sensitivity test	29
4.2.1	Guidelines for sensitivity tests	29
4.2.2	'Go/No go' tests for integrated devices.....	29
	Appendix	30
A	Reference schematics	30
A.1	Cost optimized circuit.....	30
A.2	Best performance circuit with passive antenna.....	31
A.3	Improved jamming immunity with passive antenna.....	32
A.4	Circuit using active antenna.....	33
A.5	USB self-powered circuit with passive antenna	34
A.6	USB bus-powered circuit with passive antenna	35
A.7	Circuit using 2-pin antenna supervisor	36
A.8	Circuit using 3-pin antenna supervisor	37
A.9	Design-in Recommendations in combination with cellular operation.....	38
B	Component selection	39
B.1	External RTC (Y1).....	39

B.2	RF band-pass filter (F1)	39
B.3	External LNA protection filter (F2)	40
B.4	USB line protection (D1)	40
B.5	USB LDO (U2)	40
B.6	External LNA (U1)	40
B.7	Optional SQI Flash (U3)	41
B.8	RF ESD protection diode (D2)	41
B.9	Operational amplifier (U6)	41
B.10	Open-drain buffer (U4, U7 and U8)	41
B.11	Antenna supervisor switch transistor (T1)	41
B.12	Ferrite beads (FB1)	41
B.13	Feed-thru capacitors	42
B.14	Inductor (L)	42
B.15	Standard capacitors	42
B.16	Standard resistors	42
Appendix		43
C Glossary		43
Related documents		44
Revision history		44
Contact		45

1 Hardware description

1.1 Overview

The EVA-M8M standalone concurrent GNSS modules feature the exceptional performance of the u-blox M8 positioning engine (GPS/QZSS, GLONASS, and BeiDou signals). The EVA-M8M series delivers high sensitivity and minimal acquisition times in the ultra compact EVA form factor.

The EVA-M8M series is an ideal solution for cost and space-sensitive applications. It is easy to design-in, only requiring an external GNSS antenna in most applications. The layout of the EVA-M8M modules is especially designed to ease the customer's design and limit near field interferences since RF and digital domains are kept separated.

The EVA-M8M series uses a crystal oscillator for lower system costs. Like other u-blox GNSS modules, the EVA-M8M uses components selected for functioning reliably in the field over the full operating temperature range.

With dual-frequency RF front-end, the u-blox M8 concurrent GNSS engine is able to intelligently use the highest amount of visible satellites from two GNSS (GPS, GLONASS and BeiDou) systems for reliable positioning. The EVA-M8M series comes in two variants. The EVA-M8M-0 defaults to GPS/QZSS/GLONASS and fits global applications, whereas EVA-M8M-1 defaults to GPS/QZSS/BeiDou making it the ideal module for China. The right satellite constellations can be selected without touching software, and therefore reducing the design and testing effort.

The EVA-M8M modules can be easily integrated in manufacturing, thanks to the QFN-like package and low moisture sensitivity level. The modules are available in 500 pcs/reel, ideal for small production batches. The EVA-M8M modules combine a high level of integration capability with flexible connectivity options in a miniature package. This makes them perfectly suited for industrial and mass-market end products with strict size and cost requirements. The DDC (I2C compliant) interface provides connectivity and enables synergies with u-blox cellular modules.

The EVA-M8M modules are manufactured in ISO/TS 16949 certified sites and qualified as stipulated in the JESD47 standard.



For applications needing firmware update capability or data logging, the EVA-M8M series must be connected to an external SPI Flash memory. For more information about product features, see the *EVA-M8M Data Sheet* [1].



To determine which u-blox product best meets your needs, see the product selector tables on the u-blox website www.u-blox.com.

2 Design-in

In order to obtain good performance with a GNSS receiver module, there are a number of points that require careful attention during the design-in. These include:

- **Power Supply:** Good performance requires a clean and stable power supply.
- **Interfaces:** Ensure correct wiring, rate and message setup on the module and your host system.
- **Antenna interface:** For optimal performance, seek short routing, matched impedance and no stubs.
- **External LNA:** With EVA-M8M an additional external LNA is **mandatory** if a passive antenna is used to achieve the performance values as written in the *EVA-M8M Data Sheet* [1].

2.1 Power management

2.1.1 Overview

The EVA-M8M modules provide 4 supply pins: **VCC**, **VCC_IO**, **V_BCKP** and **V_USB**. They can be supplied independently or tied together to adapt various concepts, depending on the intended application. The different supply voltages are explained in the following subsections.

Figure 1 shows an example to supply the EVA-M8M modules when not using the USB interface. In this case, the **V_USB** pin is connected to ground.

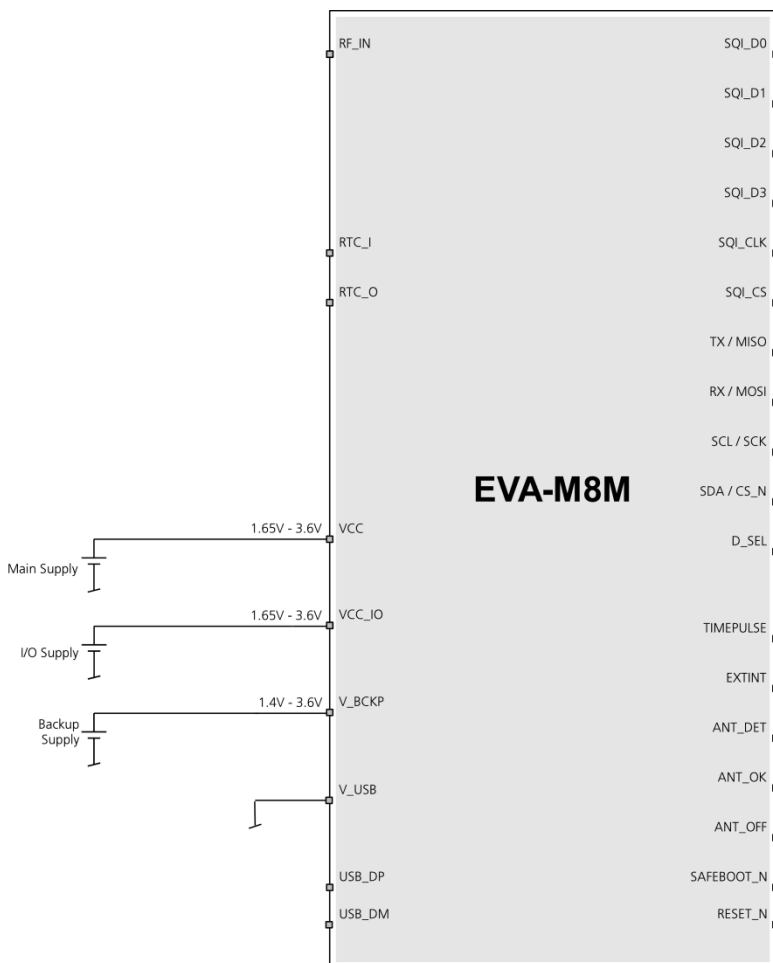



Figure 1: EVA-M8M power supply example

2.1.1.1 Main supply voltage (VCC)

During operation, the EVA-M8M modules are supplied through the **VCC** pin. It makes use of an internal DC/DC converter for improved power efficiency. In a following step, built-in LDOs generate stabilized voltages for the Core and RF domains of the chip respectively. The current at **VCC** depends heavily on the current state of the system and is in general very dynamic.

 Do not add any series resistance ($< 0.2 \Omega$) to the **VCC** supply, as it will generate input voltage noise due to the dynamic current conditions.

2.1.1.2 I/O supply voltage (VCC_IO)

The digital I/Os of the EVA-M8M modules can be supplied with a separate voltage from the host system connected to the **VCC_IO** pin of the module. The wide range of **VCC_IO** allows seamless interfacing to standard logic voltage levels. However, in most applications **VCC_IO** and **VCC** share the same voltage level and are tied together. **VCC_IO** supplies also the RTC and the backup RAM (BBR) during normal operation.

 **VCC_IO** must be supplied in order for the system to boot.

 When running the firmware from the external SQI Flash most of the VDD_IO current is consumed by the SQI bus.

2.1.1.3 Backup power supply (V_BCKP)

In the event of a power failure at **VCC_IO**, the backup domain is supplied by **V_BCKP**.

 If no backup supply is available, connect **V_BCKP** to **VCC_IO**.

 Avoid high resistance on the **V_BCKP** line: During the switch from main supply to backup supply, a short current adjustment peak can cause high voltage drop on the pin with possible malfunctions.

 If the RTC frequency is derived from the main clock, the **V_BCKP** pin also supplies the clock domain if there is a power failure at **VCC_IO**, meaning that the **V_BCKP** current will also be higher. Ensure that the capacity of the backup battery chosen meets your requirements.

2.1.1.4 USB interface power supply

V_USB supplies I/Os of the USB interface. If the USB interface is being used, the system can be either self-powered, i.e. powered independently from the USB bus, or it can be bus-powered, i.e. powered through the USB connection. In bus-powered mode, the system supply voltages need to be generated from the USB supply voltage VBUS.

 If the USB interface is not used, the **V_USB** pin must be connected to GND.

2.1.2 Power management configuration

Depending on the application, the power supply schematic will differ. Some examples are shown in the following sections:

- Single supply voltage for **VCC** and **VCC_IO**, no backup supply see Appendix, Figure 13
- Separate supply voltages for **VCC**, **VCC_IO** and **V_BCKP** see Appendix, Figure 14
- Single supply voltage for **VCC** and **VCC_IO**, use of a backup supply see Appendix, Figure 16

 For description of the different operating modes see the *EVA-M8M Data Sheet* [1].

2.2 Interfaces





The EVA-M8M modules provide UART, SPI and DDC (I²C compatible) interfaces for communication with a host CPU. A USB interface is also available on dedicated pins (see section 2.2.4). Additionally, an SQI interface is available for connecting the EVA-M8M modules with an optional external flash memory.

The UART, SPI and DDC pins are supplied by **VCC_IO** and operate at this voltage level.

Four dedicated pins can be configured as either 1 x UART and 1 x DDC or a single SPI interface selectable by **D_SEL** pin. Table 1 below provides the port mapping details.

Pin 32 (D_SEL) = "high" (left open)	Pin 32 (D_SEL) = "Low" (connected to GND)
UART TX	SPI MISO
UART RX	SPI MOSI
DDC SCL	SPI CLK
DDC SDA	SPI CS

Table 1: Communication Interfaces overview

-  It is not possible to use the SPI interface simultaneously with the DDC or UART interface.
 -  For debugging purposes, it is recommended to have a second interface e.g. USB available that is independent from the application and accessible via test-points.
- For each interface, a dedicated pin can be defined to indicate that data is ready to be transmitted. The TX Ready signal indicates that the receiver has data to transmit. A listener can wait on the TX Ready signal instead of polling the DDC or SPI interfaces. The UBX-CFG-PRT message lets you configure the polarity and the number of bytes in the buffer before the TX Ready signal goes active. The TX Ready function is disabled by default.
-  The TX Ready functionality can be enabled and configured by proper AT commands sent to the involved u-blox cellular module supporting the feature. For more information see the *GPS Implementation and Aiding Features in u-blox wireless modules* [5].
 -  The TX Ready feature is supported on version LEON FW 7.xx and LISA-U2 01S and above.

2.2.1 UART interface

A UART interface is available for serial communication to a host CPU. The UART interface supports configurable data rates with the default at 9600 baud. Signal levels are related to the **VCC_IO** supply voltage. An interface based on RS232 standard levels (+/- 7 V) can be realized using level shifter ICs such as the Maxim MAX3232.



Hardware handshake signals and synchronous operation are not supported.

A signal change on the UART RX pin can also be used to wake up the receiver in Power Save Mode (see the *u-blox M8 Receiver Description Including Protocol Specification* [2]).

2.2.2 Display Data Channel (DDC) Interface

An I²C compatible Display Data Channel (DDC) interface is available for serial communication with a host CPU.

The SCL and SDA pins have internal pull-up resistors sufficient for most applications. However, depending on the speed of the host and the load on the DDC lines additional external pull-up resistors might be necessary. For speed and clock frequency see the *EVA-M8M Data Sheet* [1].

-  To make use of DDC interface the **D_SEL** pin has to be left open.
-  The EVA-M8M DDC interface provides serial communication with u-blox cellular modules. See the specification of the applicable cellular module to confirm compatibility.

For more information about DDC implementation refer to the *u-blox M8 Receiver Description Including Protocol Specification* [2].

2.2.3 SPI Interface

The SPI interface can be used to provide a serial communication with a host CPU. If the SPI interface is used, UART and DDC are deactivated, because they share the same pins.



To make use of the SPI interface, the **D_SEL** pin has to be connected to GND.

2.2.4 USB interface

The USB interface of the EVA-M8M modules support the full-speed data rate of 12 Mbit/s. It is compatible to the USB 2.0 FS standard. The interface requires some external components in order to implement the physical characteristics required by the USB 2.0 specification. Figure 2 shows the interface pins and additional external components. In order to comply with USB specifications, VBUS must be connected through a LDO (U2) to pin **V_USB** of the EVA-M8M series. This ensures that the internal 1.5 k Ω pull-up resistor on **USB_DP** gets disconnected when the USB host shuts down VBUS.

Depending on the characteristics of the LDO (U2), for a self-powered design it is recommended to add a pull-down resistor (R8) at its output to ensure **V_USB** does not float if a USB cable is not connected, i.e. when VBUS is not present.

The interface can be used either in “self powered” or “bus powered” mode. The required mode can be configured using the UBX-CFG-USB message. Also, the vendor ID, vendor string, product ID and product string can be changed.

In order to get the 90 Ω differential impedance in between the **USB_DM** and **USB_DP** data line, a 27 Ω series resistor (R1, R2) must be placed into each data line (**USB_DM** and **USB_DP**).

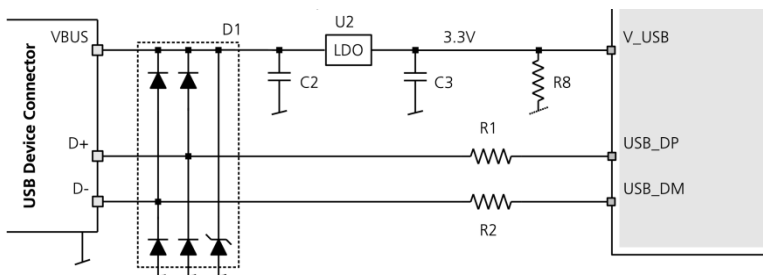

Figure 2: USB interface

Name	Component	Function	Comments
U2	LDO	Regulates VBUS (4.4 ... 5.25 V) down to a voltage of 3.3 V.	Almost no current requirement (~1 mA) if the GNSS receiver is operated as a USB self-powered device, but if bus-powered LDO (U2) must be able to deliver the maximum current of ~100 mA.
C2,C3	Capacitors		Required according to the specification of LDO U2
D1	Protection diodes	Protect circuit from overvoltage / ESD when connecting.	Use low capacitance ESD protection such as ST Microelectronics USBL6-2.
R1, R2	Serial termination resistors	Establish a full-speed driver impedance of 28...44 Ω	A value of 27 Ω is recommended.
R8	Resistor	Ensures defined signal at V_USB when VBUS is not connected / powered	100 k Ω is recommended for USB self-powered setup. For bus-powered setup R8 is not required.

Table 2: Summary of USB external components

See Appendix A.5 and Appendix A.6 for reference schematics for self- and bus-powered operation.



If the USB interface is not used, connect **V_USB** to GND.

2.2.5 SQI Flash memory

An external SQI (Serial Quad Interface) Flash memory can be connected to the EVA-M8M SQI interface to provide the following options:

- Run firmware out of the SQI Flash and have the possibility to update the firmware
- Store the current configuration permanently
- Save data logging results
- Hold AssistNow Offline and AssistNow Autonomous data



An SQI Flash must be connected when firmware update is a prime requirement.



The EVA-M8M modules can make use of a dedicated flash firmware with an external SQI Flash memory. The voltage level of the SQI interface follows the VCC_IO level. Therefore, the SQI Flash must be supplied with the same voltage as VCC_IO of the EVA-M8M. It is recommended to place a decoupling capacitor (C4) close to the supply pin of the SQI Flash.



Make sure that the SQI Flash supply range matches the voltage supplied at VCC_IO.

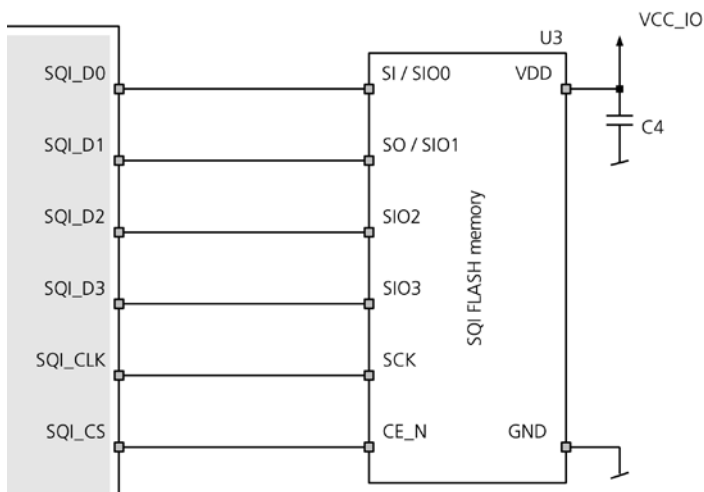

Figure 3 : Connecting an external SQI Flash memory

Running the firmware from the SQI Flash requires a minimum SQI Flash size of 8 Mbit. An 8 Mbit device is also sufficient to save AssistNow Offline and AssistNow Autonomous information as well as Current configuration data. However, to run Firmware from the SQI Flash and provide space for logging results, a minimum size of 8 Mbit might not be sufficient depending on the amount of data to be logged.



For more information about supported SQI Flash devices see Table 17.

There is a configurable VCC_IO monitor threshold (iomonCfg) to ensure that the EVA-M8M receivers only start if the VCC_IO supply (which is used to supply the SQI Flash), is within the supply range of the SQI Flash device. This will ensure that any connected SQI Flash memory will be detected correctly at startup. By default the VCC_IO monitor threshold is set for using a 1.8 V Flash memory device.



The VCC_IO monitor threshold (iomonCfg) must be set according to the SQI supply voltage level (VCC_IO).

When using a 3.0 V or a 3.3 V flash memory device send one of the following sequences to the EVA-M8M receiver in production:

B5 62 06 41 0C 00 00 00 03 1F 20 EC 68 C6 FE 7F FE FF 29 3E (for a 3.0 V Flash memory)

B5 62 06 41 0C 00 00 00 03 1F 6B 74 EB FD FE 7F 7E FF 36 73 (for a 3.3 V Flash memory)



Applying these sequences result in a permanent change and cannot be reversed.



Make sure that the SAFEBOOT_N pin is available for entering Safe Boot Mode. Programming the SQI Flash memory with a Flash firmware is done typically at production. For this purpose the EVA-M8M modules have to enter the Safe Boot Mode. More information about SAFEBOOT_N pin see section 2.6.



When the EVA-M8M-1 variant is attached with an external SQI flash without running a Flash firmware, the default concurrent reception of GPS/QZSS/SBAS and BeiDou remains unchanged. In case the Flash is also used for execution of firmware update, the default reception will be reset to GPS/QZSS/SBAS and GLONASS. EVA-M8M-1 can be changed back to concurrent GPS/QZSS/SBAS and BeiDou by sending a dedicated UBX message (**UBX-CFG-GNSS**) to the module. More information see the *u-blox M8 Receiver Description Including Protocol Specification* [2].

2.3 I/O Pins

All I/O pins make use of internal pull-ups. Thus, there is no need to connect unused pins to **VCC_IO**.

2.3.1 Time pulse

A configurable time pulse signal is available and configured by default to 1 pulse per second. For further information see the *u-blox M8 Receiver Description Including Protocol Specification* [2].

2.3.2 External interrupt

EXTINT is an external interrupt pin with fixed input voltage thresholds with respect to **VCC_IO** (see the *EVA-M8M Data Sheet* [1] for more information). It can be used for wake-up functions in Power Save Mode on all u-blox M8 modules and for aiding. Leave open if unused; its function is disabled by default. By default the external interrupt is disabled.

For further information see the *u-blox M8 Receiver Description Including Protocol Specification* [2].



If the EXTINT is configured for on/off switching of the EVA-M8M series, the internal pull-up becomes disabled. Thus make sure the EXTINT input is always driven within the defined voltage level by the host.

2.3.3 Active antenna supervisor

EVA-M8M modules support active antenna supervisors. The antenna supervisor gives information about the status of the active antenna and will turn off the supply to the active antenna in case a short is detected or to optimize the power consumption when in Power Save Mode.

There is either a 2-pin or a 3-pin antenna supervisor. By default the 2-pin antenna supervisor is enabled.

2.3.3.1 2-pin antenna supervisor

The 2-pin antenna supervisor function, which is enabled by default, consists of the **ANT_OK** input and the **ANT_OFF** output pins.

Function	I/O	Description	Remarks
ANT_OK	I	Antenna OK "high" = Antenna OK "low" = Antenna not OK	Default configuration
ANT_OFF	O	Control signal to turn on and off the antenna supply "high" = Antenna OFF "low" = Antenna ON	Default configuration

Table 3: 2-pin antenna supervisor pins

The circuitry, as shown in Appendix A.7 (see Figure 19) provides antenna supply short circuit detection. It will prevent antenna operation via transistor T1 if a short circuit has been detected or if it is not required (e.g. in Power Save Mode).

The status of the active antenna can be checked by the UBX-MON-HW message. More information see the *u-blox M8 Receiver Description Including Protocol Specification* [2].

Open drain buffers U4 and U7 (e.g. Fairchild NC7WZ07) are needed to shift the voltage levels. R3 is required as a passive pull-up to control T1 because U4 has an open drain output. R4 serves as a current limiter in the event of a short circuit.

2.3.3.2 3-pin antenna supervisor

The 3-pin antenna supervisor is comprised of the **ANT_DET** (active antenna detection), **ANT_SHORT_N** (short detection) and **ANT_OFF** (antenna on/off control) pins. This function must be activated by sending the following sequence to the EVA-M8M receivers in production:

```
B5 62 06 41 0C 00 00 00 03 1F CD 1A 38 57 FF FF F6 FF DE 11
```



Applying this sequence results in a permanent change and cannot be reversed.

Function	I/O	Description	Remarks
ANT_DET	I (pull-up)	Antenna detected "high" = Antenna detected "low" = Antenna not detected	Byte sequence given in section 2.3.3.2 should be applied.
ANT_SHORT_N	I (pull-up)	Antenna not shorted "high" = antenna has no short "low" = antenna has a short	Byte sequence given in section 2.3.3.2 should be applied.
ANT_OFF	O	Control signal to turn on and off the antenna supply "high" = turn off antenna supply "low" = short to GND	Byte sequence given in section 2.3.3.2 should be applied.

Table 4: 3-pin Antenna supervisor pins

The external circuitry, as shown in Appendix A.8, (see Figure 20) provides detection of an active antenna connection status. If the active antenna is present, the DC supply current exceeds a preset threshold defined by R4, R5, and R6. It will shut down the antenna via transistor T1 if a short circuit has been detected via U7 or if it's not required (e.g. in Power Save Mode).

The status of the active antenna can be checked by the UBX-MON-HW message. More information see the *u-blox M8 Receiver Description Including Protocol Specification* [2].

The open drain buffers U4, U7 and U8 (e.g. Fairchild NC7WZ07) are needed to shift the voltage levels. R3 is required as a passive pull-up to control T1 because U4 has an open drain output. R4 serves as a current limiter in the event of a short circuit.

2.3.4 Electromagnetic interference on I/O lines

Any I/O signal line (length > ~3 mm) may pick up high frequency signals and transfer this noise into the GNSS receiver. This specifically applies to unshielded lines, lines where the corresponding GND layer is remote or missing entirely, and lines close to the edges of the printed circuit board. If a GSM signal radiates into an unshielded high-impedance line, noise in the order of volts can be generated and possibly not only distort receiver operation but also damage it permanently.

In such case it is recommended to use feed-thru capacitors with good GND connection close to the GNSS receiver in order to filter such high-frequency noise. See Appendix B.13 for component recommendations. Alternatively, ferrite beads (see Appendix B.12) or resistors can be used. These work without GND connection but may adversely affect signal rise time.

EMI protection measures are recommended when RF emitting devices are near the GNSS receiver. To minimize the effect of EMI, a robust grounding concept is essential. To achieve electromagnetic robustness, follow the standard EMI suppression techniques.

2.4 Real-Time Clock (RTC)

The use of the RTC is optional to maintain time in the event of power failure at **VCC_IO**. The RTC is required for hot start, warm start, AssistNow Autonomous, AssistNow Offline and in some Power Save Mode operations.

The time information can either be generated by connecting an external RTC crystal to the EVA-M8M modules, by deriving the RTC from the internal crystal oscillator, by connecting an external 32.768 kHz signal to the RTC input, or by time aiding of the GNSS receiver at every startup.

2.4.1 RTC using a crystal

The easiest way to provide time information to the receiver is to connect an RTC crystal to the corresponding pins of the RTC oscillator, **RTC_I** and **RTC_O**. There is no need to add load capacitors to the crystal for frequency tuning, because they are already integrated in the chip. Using an RTC crystal will provide the lowest current consumption to **V_BCKP** in case of a power failure. On the other hand, it will increase the BOM costs and requires space for the RTC crystal.

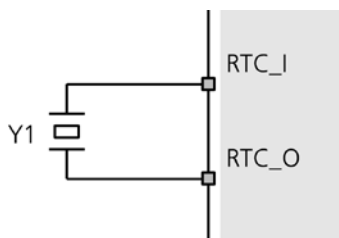

Figure 4: RTC crystal

2.4.2 RTC derived from the system clock

The EVA-M8M modules can be configured in such way that the reference frequency for the RTC is internally derived from the 26 MHz crystal oscillator. For this feature **RTC_I** must be connected to ground and **RTC_O** left open. The capacity of the backup battery at **V_BCKP** must be dimensioned accordingly, taking into account the higher than normal current consumption at **V_BCKP** in the event of power failure at **VCC_IO**.

The single crystal feature can be configured by sending the following sequence to the receiver:

```
B5 62 06 41 0C 00 00 00 03 1F 47 F2 D7 AD FF FF FC FF 2B 3D
```



Applying this sequence results in a permanent change and cannot be reversed.

2.4.3 RTC using an external clock

Some applications can provide a suitable 32.768 kHz external reference to drive the EVA-M8M RTC. The external reference can simply be connected to the **RTC_I** pin. Make sure that the 32.768 kHz reference signal is always turned on and the voltage at the **RTC_I** pin does not exceed 350 mVpp. Adjusting of the voltage level (typ. 200 mVpp) can be achieved with a resistive voltage divider followed by a DC blocking capacitor in the range of 1 nF to 10 nF. Also make sure the frequency versus temperature behavior of the external clock is within the recommended crystal specification shown in section B.1.

2.4.4 Time aiding

Time can also be sent by UBX message at every startup of the EVA-M8M modules. This can be done to enable warm starts, AssistNow Autonomous and AssistNow Offline. This can be done when no RTC is maintained.

To enable hot starts correctly, the time information must be known accurately and thus the TimeMark feature has to be used.

For more information about time aiding or timemark see the *u-blox M8 Receiver Description Including Protocol Specification* [2].



For information of this use case, it is mandatory to contact u-blox support team.



For Power Save Mode operations where the RTC is needed, the time aiding cannot be used. This is because the host does not have any information about when the EVA-M8M series turns from OFF status to ON status during ON/OFF operation of Power Save Mode.

2.5 RF input

The EVA-M8M modules RF-input is already matched to 50 Ohms and has an internal DC block. To achieve the performance values as written in the *EVA-M8M Data Sheet* [1], an active antenna with a good LNA inside or the mandatory LNA with passive antenna in front of EVA-M8M (must have a noise figure below 1dB).

The EVA-M8M modules can receive and track multiple GNSS system (e.g. GPS/QZSS, GLONASS, and BeiDou signals). Because of the dual-frequency RF front-end architecture, two of the three signals (GPS L1C/A, GLONASS L1OF and BeiDou B1) can be received and processed concurrently.

2.5.1 Active Antenna

In case an active antenna is used, just the active antenna supply circuit has to be added in front of the EVA-M8M modules RF-input, see Figure 16. In case the active antenna has to be supervised, either the 2-pin active antenna supervisor circuit (see Figure 19) or the 3-pin active antenna supervisor circuit (see Figure 20), has to be added to the active antenna circuit. These active antenna supervisor circuits also make sure that the active antenna is turned off in Power Save Mode stages.

2.5.2 Passive Antenna

If a passive antenna is connected to the EVA-M8M modules, it is mandatory to use an additional LNA in front of EVA-M8M to achieve the performance values as written in the *EVA-M8M Data Sheet* [1], see Annex A. An LNA (U1) alone would make the EVA-M8M modules more sensitive to out-band jammers, so an additional GNSS SAW filter (F1) has to be connected between the external LNA (U1) and the EVA-M8M RF-input. If strong out-band jammers are close to the GNSS antenna (e.g. a GSM antenna), see section 2.5.3.

The LNA (U1) can be selected to deliver the performance needed by the application in terms of:

- Noise figure (sensitivity)
- Selectivity and linearity (Robustness against jamming)
- Robustness against RF power and ESD



The external LNA (U1) must be placed close to the passive antenna to get best performance.

The **ANT_OFF** pin can be used to turn off an external LNA. The **ANT_OFF** signal must be inverted for common LNAs which come with an enable pin which has to be "low" to turn off.

The function of the **ANT_OFF** pin can be inverted by sending the following sequence to the receiver:

```
B5 62 06 41 0C 00 00 00 03 1F 90 47 4F B1 FF FF EA FF 33 98
```



Applying this sequence results in a permanent change and cannot be reversed.



A pull-down resistor (R7) is required to ensure correct operation of the **ANT_OFF** pin.

ESD discharge into the RF input cannot always be avoided during assembly and / or field use with this approach! To provide additional robustness an ESD protection diode, as listed in Appendix B.7, can be placed in front of the LNA to GND.

2.5.3 Improved Jamming Immunity

If strong out-band jammers are close to the GNSS antenna (e.g. a GSM antenna) GNSS performance can be degraded or the maximum input power of the EVA-M8M series RF-input can be exceeded. An additional SAW filter (F2) has to be put in front of the external LNA (U1), see Appendix A. If the external LNA can accept the maximum input power, the SAW filter between the passive antenna and external LNA (LNA1) might not be necessary. This results in a better noise figure than an additional SAW filter (F2) in front of the external LNA (U1).

If the EVA-M8M modules are exposed to an interference environment, it is recommended to use additional filtering. Improved interference immunity with good GNSS performance can be achieved when using a SAW/LNA/SAW configuration between the antenna and the EVA-M8M RF-input. The single-ended SAW filter (F2) can be placed in front of the LNA matching network to prevent receiver blocking due to strong interference, see Figure 15.

It should be noted that the insertion loss of SAW filter (F2) directly affects the system noise figure and hence the system performance. Choice of a component with low insertion loss is mandatory when a passive antenna is used with this set-up. An example schematic for an improved jamming immunity is shown in Appendix A.3 (see Figure 15).

2.6 Safe Boot Mode (SAFEBOOT_N pin)

If the SAFEBOOT_N pin is “low” at start up, the EVA-M8M series starts in Safe Boot Mode and doesn’t begin GNSS operation. In Safe Boot Mode the EVA-M8M series runs from an internal LC oscillator and starts regardless of any configuration provided by the configuration pins. Thus it can be used to recover from situations where the SQI Flash has become corrupted.

Owing to the inaccurate frequency of the internal LC oscillator, the EVA-M8M series is unable to communicate via USB in Safe Boot Mode. For communication by UART in Safe Boot Mode, a training sequence (0x 55 55 at 9600 baud) can be sent by the host to the EVA-M8M in order to enable communication. After sending the training sequence, the host has to wait for at least 2 ms before sending messages to the EVA-M8M receivers. For further information see the *u-blox M8 Receiver Description Including Protocol Specification* [2].

Safe Boot Mode is used in production to program the SQI Flash. It is recommended to have the possibility to pull the SAFEBOOT_N pin “low” when the EVA-M8M series starts up. This can be provided using an externally connected test point or via a host CPUs digital I/O port.

2.7 RESET_N

The EVA-M8M modules provide a **RESET_N** pin to reset the system. The **RESET_N** is an input-only with internal pull-up resistor. It must be at low level for at least 10 ms to make sure **RESET_N** is detected. It is used to reset the system. Leave **RESET_N** open for normal operation. The **RESET_N** complies with the **VCC_IO** level and can be actively driven high.



RESET_N should be only used in critical situations to recover the system. The Real-Time Clock (RTC) will also be reset and thus immediately afterwards the receiver cannot perform a Hot Start.



In reset state, the EVA-M8M series consumes a significant amount of current. It is therefore recommended to use **RESET_N** only as a reset signal and not as an enable/disable.

2.8 Design-in checklist

2.8.1 General considerations

Check power supply requirements and schematic:

- Is the power supply voltage within the specified range? See how to connect power in Section 2.1.
- For USB devices: Is the voltage **V_USB** voltage within the specified range? Do you have a Bus or Self powered setup?
- Compare the peak current consumption of EVA-M8M series with the specification of your power supply.
- GNSS receivers require a stable power supply. Avoid series resistance in your power supply line (the line to **VCC**) to minimize the voltage ripple on **VCC**.

Backup battery

- For achieving a minimal Time To First Fix (TTFF) after a power down (warm starts, hot starts), make sure to connect a backup battery to **V_BCKP**, and use an RTC. If not used, make sure **V_BCKP** is connected to **VCC_IO**.

Antenna/ RF input

- The total noise figure including external LNA (or the LNA in the active antenna) should be around 1 dB.
- With the EVA-M8M series, an external LNA is mandatory if no active antenna is used to achieve the performance values as written in the *EVA-M8M Data Sheet* [1].
- Make sure the antenna is not placed close to noisy parts of the circuitry and not facing noisy parts. (e.g. micro-controller, display, etc.)
- To optimize performance in environments with out-band jamming/interference sources, use an additional SAW filter.



For more information dealing with interference issues see the *GPS Antenna Application Note* [3].

Schematic

- Inner pins of the package must all be connected to GND.**

2.8.2 Schematic design-in for EVA-M8M

For a minimal design with the EVA-M8M the following functions and pins need to be considered:

- Connect the power supply to **VCC**, **VCC_IO** and **V_BCKP**.
- **V_USB**: Connect the USB power supply to a LDO before feeding it to **V_USB** and **VCC** or connect it to GND if USB is not used.
- Ensure an optimal ground connection to all ground pins of the EVA-M8M modules
- Choose the required serial communication interfaces (UART, USB, SPI or DDC) and connect the appropriate pins to your application
- If you need hot or warm start in your application, connect a Backup Battery to **V_BCKP** and add RTC circuit.
- If antenna bias is required, see Appendix A.4.

2.9 Pin description

Name	I/O	Description	Remark
ANT_OFF	O	Antenna control	Leave open if not used.
ANT_OK	I	Antenna status	Leave open if not used.
D_SEL	I	Interface selector	See section 2.2.
GND	I	Ground	Outer ground pin
GND	I	Ground	Outer ground pin
GND	I	Ground	Inner ground pin
GND	I	Ground	Inner ground pin
GND	I	Ground	Inner ground pin
GND	I	Ground	Inner ground pin
GND	I	Ground	Inner ground pin
GND	I	Ground	Inner ground pin
GND	I	Ground	Inner ground pin
PIO13 / EXTINT	I	External interrupt	Leave open if not used.
PIO14 / ANT_DET	I	Antenna detection	Leave open if not used.
Reserved	I/O	Reserved	Do not connect. Must be left open!
Reserved	I/O	Reserved	Do not connect. Must be left open!
Reserved	I/O	Reserved	Do not connect. Must be left open!
Reserved	I/O	Reserved	Do not connect. Must be left open!
Reserved	I/O	Reserved	Do not connect. Must be left open!
SQL_D0	I/O	Data line 0 to external SQL flash memory or reserved configuration pin.	Leave open if not used.
SQL_CLK	I/O	Clock for external SQL flash memory or configuration pin.	Leave open if not used.
cSQL_D2	I/O	Data line 2 to external SQL flash memory or reserved configuration pin.	Leave open if not used.
SQL_D1	I/O	Data line 1 to external SQL flash memory or reserved configuration pin.	Leave open if not used.
SQL_CS	I/O	Chip select for external SQL flash memory or configuration enable pin.	Leave open if not used.
SQL_D3	I/O	Data line 3 to external SQL flash memory or reserved configuration pin.	Leave open if not used.
Reserved	I/O	Reserved	Do not connect. Must be left open!
SAFEBOOT_N	I	Used for programming the SQL flash memory and testing purposes.	Leave open if not used.
Reserved	I/O	Reserved	Do not connect. Must be left open!
RESET_N	I	System reset	See section 2.7.
RF_IN	I	RF Input	Add external LNA and SAW if no active antenna used.
RTC_O	O	RTC Output	Leave open if no RTC Crystal attached.
RTC_I	I	RTC Input	Connect to GND if no RTC Crystal attached.
RX / MOSI	I	Serial interface	See section 2.2.
SCL / SCK	I	Serial interface	See section 2.2.
SDA / CS_N	I/O	Serial interface	See section 2.2.
TIMEPULSE	O	Time pulse output	Leave open if not used.
TX / MISO	O	Serial interface	See section 2.2.
USB_DM	I/O	USB data	Leave open if not used.
USB_DP	I/O	USB data	Leave open if not used.
V_BCKP	I	Backup supply	See section 2.1.
VCC	I	Main supply	See section 2.1.
VCC_IO	I	I/O Supply	See section 2.1.
V_USB	I	USB Interface power	Connect to GND if not used.

Table 5: EVA-M8M pin description



For pin assignment see the *EVA-M8M Data Sheet* [1].

2.10 Layout design-in checklist

Follow this checklist for the layout design to get an optimal GNSS performance.

Layout optimizations (Section 2.11)

- Is the EVA-M8M placed according to the recommendation in section 2.11.3?
- Is the grounding concept optimal?
- Has the 50 Ohm line from antenna to EVA-M8M (micro strip / coplanar waveguide) been kept as short as possible?
- Assure low serial resistance in **VCC** power supply line (choose a line width > 400 um).
- Keep power supply line as short as possible.
- Design a GND guard ring around the optional RTC crystal lines and GND below the RTC circuit.
- Add a ground plane underneath the GNSS module to reduce interference. This is especially important for the RF input line.
- For improved shielding, add as many vias as possible around the micro strip/coplanar waveguide, around the serial communication lines, underneath the GNSS module, etc.

Calculation of the micro strip for RF input

- The micro strip / coplanar waveguide must be 50 Ohms and be routed in a section of the PCB where minimal interference from noise sources can be expected. Make sure around the RF line is only GND as well as under the RF line.
- In case of a multi-layer PCB, use the thickness of the dielectric between the signal and the 1st GND layer (typically the 2nd layer) for the micro strip / coplanar waveguide calculation.
- If the distance between the micro strip and the adjacent GND area (on the same layer) does not exceed 5 times the track width of the micro strip, use the "Coplanar Waveguide" model in AppCad to calculate the micro strip and not the "micro strip" model.

2.11 Layout

This section provides important information for designing a reliable and sensitive GNSS system.

GNSS signals at the surface of the earth are about 15 dB below the thermal noise floor. Signal loss at the antenna and the RF connection must be minimized as much as possible. When defining a GNSS receiver layout, the placement of the antenna with respect to the receiver, as well as grounding, shielding and jamming from other digital devices are crucial issues and need to be considered very carefully.

2.11.1 Footprint

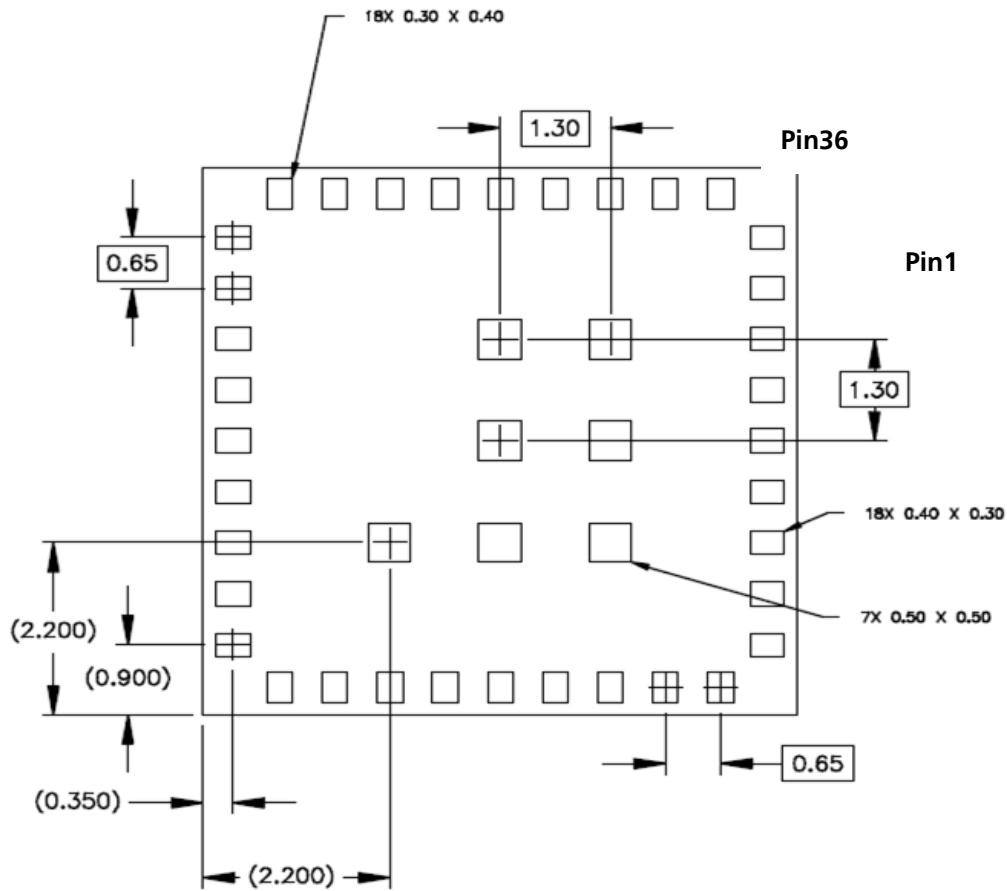

Figure 5: Recommended footprint (bottom view)

Units are in mm.

2.11.2 Paste mask

The paste mask shall be 50 μm smaller than the copper pads with a paste thickness of 100 μm .



The paste mask outline needs to be considered when defining the minimal distance to the next component.



These are recommendations only and not specifications. The exact geometry, distances, stencil thicknesses and solder paste volumes must be adapted to the specific production processes (e.g. soldering etc.) of the customer.

2.11.3 Placement

A very important factor in achieving maximum GNSS performance is the placement of the receiver on the PCB. The connection to the antenna must be as short as possible to avoid jamming into the very sensitive RF section.

Make sure that RF critical circuits are clearly separated from any other digital circuits on the system board. To achieve this, position the receiver digital part towards your digital section of the system PCB. Care must also be exercised with placing the receiver in proximity to circuitry that can emit heat. The RF part of the receiver is very sensitive to temperature and sudden changes can have an adverse impact on performance.



High temperature drift and air vents can affect the GNSS performance. For best performance avoid high temperature drift and air vents near the module.

2.12 Migration considerations

EVA-M8M series is the successor of the EVA-7M. u-blox is committed to ensuring that products in the same form factor are backwards compatible over several technology generations. Utmost care has been taken to ensure there is no negative impact on function or performance and to make u-blox M8 modules as fully compatible as possible with u-blox 7 versions. No limitations of the standard features have resulted. If using BeiDou, check the bandwidth of the external RF components and the antenna. For power consumption information, see the *EVA-M8M Data Sheet* [1].

In contrast to EVA-7M, the EVA-M8M series provides flash firmware update capabilities when connecting an external SQI flash memory device. In addition, the SQI Flash memory allows for the usage of data logging and increases AssistNow Offline and Autonomous performances. More information and recommendations for using an external SQI flash see section 2.2.5. It is highly advisable that customers consider a design review with the u-blox support team to ensure the compatibility of key functionalities.



For an overall description of the module software operation, see the *u-blox M8 Receiver Description Including Protocol Specification* [2].



For migration, see the *u-blox 7 to u-blox M8 Software Migration Guide* [6].

2.12.1 C88-M8M - Evaluating EVA-M8M on existing NEO-xM sockets

The C88-M8M GNSS application board is designed for easier evaluation and design-in of u-blox EVA-M8M modules in existing NEO-xM modules based products. The C88-M8M series integrates the EVA-M8M GNSS modules into a NEO form factor adaptor board (i.e. with the same dimensions and pinout as the NEO-6M, NEO-7M and NEO-M8M). The C88-M8M application board allows straightforward integration of the u-blox EVA-M8M modules in customers' existing end products based on the u-blox NEO GNSS modules. It enables fast verification of the EVA-M8M functionalities and performances before the design-in.



Schematic of C88-M8M is available upon request.

Pin	NEO-6M		C88-M8M		Remarks for Migration
	Pin Name	Typical Assignment	Pin Name	Typical Assignment	
1	RESERVED	SAFEBOOT_N (Leave open)	RESERVED	SAFEBOOT_N (Leave open)	No difference
2	SS_N	SPI Slave Select	D_SEL	Leave open. If connected to GND SPI interface available on Pins 18-21.	Different functions. Only compatible if this pin is left open!
3	TIMEPULSE	Time pulse (1PPS)	TIMEPULSE	Time pulse (1PPS)	No difference
4	EXTINT0	External interrupt pin	EXTINT0	External interrupt pin	No difference
5	USB_DM	USB data	USB_DM	USB Data	No difference
6	USB_DP	USB data	USB_DP	USB Data	No difference
7	VDD_USB	USB supply	VDD_USB	USB supply	No difference

Pin	NEO-6M		C88-M8M		Remarks for Migration
	Pin Name	Typical Assignment	Pin Name	Typical Assignment	
8	RESERVED	Pin 8 and 9 must be connected together.	RESET_N	Reset input	If pin 8 is connected to pin 9 on C88-M8M, the device always runs. With NEO-6Q, if Reset input is used, it implements the 3k3 resistor from pin 8 to pin 9. This also works with NEO-7N. If used with NEO-7N, do not populate the pull-up resistor.
9	VCC_RF	Can be used for active antenna or external LNA supply.	VCC_RF	Can be used for active antenna or external LNA supply.	No difference
10	GND	GND	GND	GND	No difference
11	RF_IN	GPS signal input	RF_IN	GPS signal input	For designs with a passive antenna directly connected to the RF_IN pin, an additional LNA in front of C88-M8M is recommended in order to achieve the performance values shown in the <i>EVA-M8M Data Sheet</i> [1]. The Noise Figure of the C88-M8M is about 2 dB higher than NEO-6M.
12	GND	GND	GND	GND	No difference
13	GND	GND	GND	GND	No difference
14	MOSI/ CFG_COM0	SPI MOSI / Configuration pin. Leave open if not used.	RESERVED	Leave open.	Different functions. Only compatible if this pin is left open!
15	MISO/ CFG_COM1	SPI MISO / Configuration pin. Leave open if not used.	RESERVED	Leave open.	Different functions. Only compatible if this pin is left open!
16	CFG_GPS0/ SCK	Power Mode Configuration pin / SPI Clock. Leave open if not used.	RESERVED	Leave open.	Different functions. Only compatible if this pin is left open!
17	RESERVED	Leave open.	RESERVED	Leave open.	No difference
18	SDA	DDC Data	SDA	DDC Data / SPI CS_N	No difference if pin 2 is left open. If pin 2 low = SPI chip select.
19	SCL	DDC Clock	SCL	DDC Clock / SPI SCK	No difference for DDC. If pin 2 low = SPI clock.
20	TxD	Serial Port	TxD	Serial Port / SPI MISO	No difference for UART. If pin 2 low = SPI MISO.
21	RxD	Serial Port	RxD	Serial Port / SPI MOSI	No difference for UART. If pin 2 low = SPI MOSI.
22	V_BCKP	Backup supply voltage	V_BCKP	Backup supply voltage	No difference
23	VCC	Supply voltage	VCC	Supply voltage	
24	GND	GND	GND	GND	No difference

Table 6: Replacing NEO-6M by C88-M8M



NEO-6M **cannot** be replaced by C88-M8M if SPI interface or configuration pins (pin 2, pin 14, pin 15 and pin 16) are used.



For the existing NEO-7M and NEO-M8M designs, C88-M8M is one to one compatible with the exception of some performance difference.

2.13 EOS/ESD/EMI precautions

When integrating GNSS receivers into wireless systems, careful consideration must be given to electromagnetic and voltage susceptibility issues. Wireless systems include components which can produce Electrostatic Discharge (ESD), Electrical Overstress (EOS) and Electro-Magnetic Interference (EMI). CMOS devices are more sensitive to such influences because their failure mechanism is defined by the applied voltage, whereas bipolar semiconductors are more susceptible to thermal overstress. The following design guidelines are provided to help in designing robust yet cost effective solutions.

-  To avoid overstress damage during production or in the field it is essential to observe strict EOS/ESD/EMI handling and protection measures.
-  To prevent overstress damage at the RF_IN of your receiver, never exceed the maximum input power as specified in the *EVA-M8M Data Sheet* [1].

2.13.1 Electrostatic Discharge (ESD)

Electrostatic discharge (ESD) is the sudden and momentary electric current that flows between two objects at different electrical potentials caused by direct contact or induced by an electrostatic field. The term is usually used in the electronics and other industries to describe momentary unwanted currents that may cause damage to electronic equipment.



2.13.2 ESD protection measures

-  GNSS receivers are sensitive to Electrostatic Discharge (ESD). Special precautions are required when handling.

Most defects caused by ESD can be prevented by following strict ESD protection rules for production and handling. When implementing passive antenna patches or external antenna connection points, then additional ESD measures as shown in Figure 6 can also avoid failures in the field.

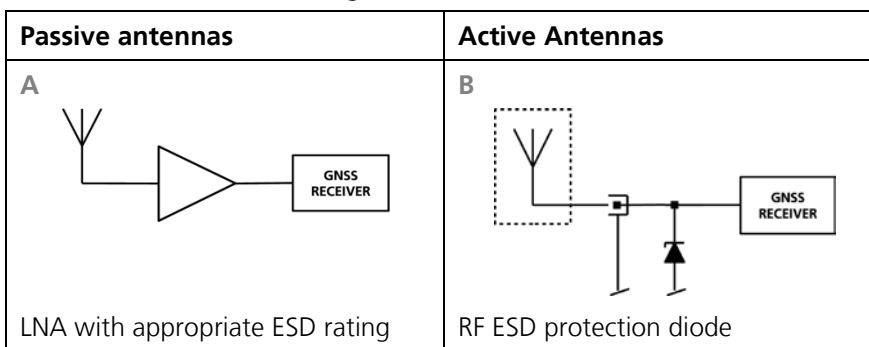

Figure 6: ESD Precautions

2.13.3 Electrical Overstress (EOS)

Electrical Overstress (EOS) usually describes situations when the maximum input power exceeds the maximum specified ratings. EOS failure can happen if RF emitters are close to a GNSS receiver or its antenna. EOS causes damage to the chip structures.

If the **RF_IN** is damaged by EOS, it's hard to determine whether the chip structures have been damaged by ESD or EOS.

2.13.4 EOS protection measures

EOS protection measures as shown in Figure 7 are recommended for any designs combining wireless communication transceivers (e.g. GSM, GPRS) and GNSS in the same design or in close proximity.

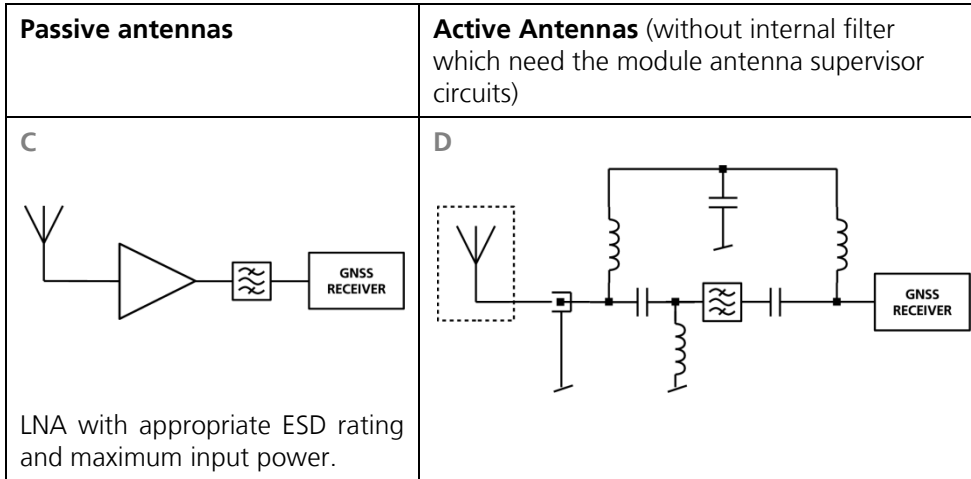

Figure 7: EOS and ESD Precautions

2.13.5 Applications with cellular modules

GSM uses power levels up to 2W (+33dBm). Make sure that absolute maximum input power level of the GNSS receiver is not exceeded.

See the *GPS Implementation and Aiding Features in u-blox wireless modules* [5].

2.13.5.1 Isolation between GNSS and GSM antenna

In a handheld type design, an isolation of approximately 20 dB can be reached with careful placement of the antennas. If such isolation can't be achieved, e.g. in the case of an integrated GSM/GNSS antenna, an additional input filter is needed on the GNSS side to block the high energy emitted by the GSM transmitter. Examples of these kinds of filters would be the SAW Filters from Epcos (B9444 or B7839) or Murata.

2.13.5.2 Increasing interference immunity

Interference signals come from in-band and out-band frequency sources.

2.13.5.3 In-band interference

With in-band interference, the signal frequency is very close to the GPS frequency of 1575 MHz (see Figure 8). Such interference signals are typically caused by harmonics from displays, micro-controller, bus systems, etc.

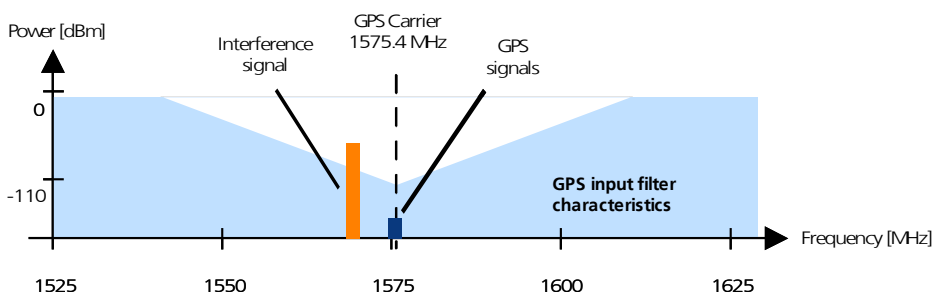

Figure 8: In-band interference signals

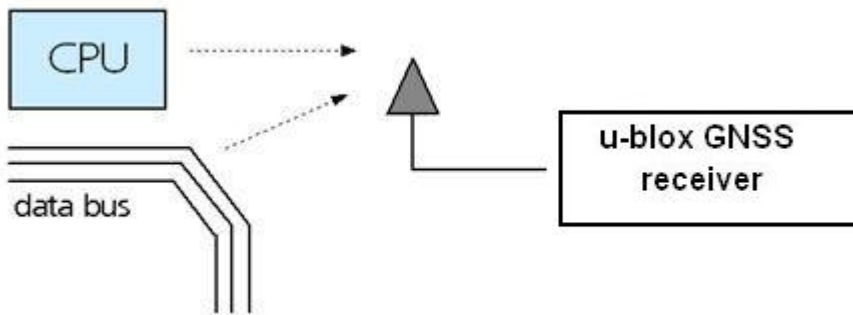

Figure 9: In-band interference sources

Measures against in-band interference include:

- Maintaining a good grounding concept in the design
- Shielding
- Layout optimization
- Filtering
- Placement of the GNSS antenna
- Adding a CDMA, GSM, WCDMA bandpass filter before handset antenna

2.13.5.4 Out-band interference

Out-band interference is caused by signal frequencies that are different from the GNSS carrier (see Figure 10). The main sources are wireless communication systems such as GSM, CDMA, WCDMA, WiFi, BT, etc.

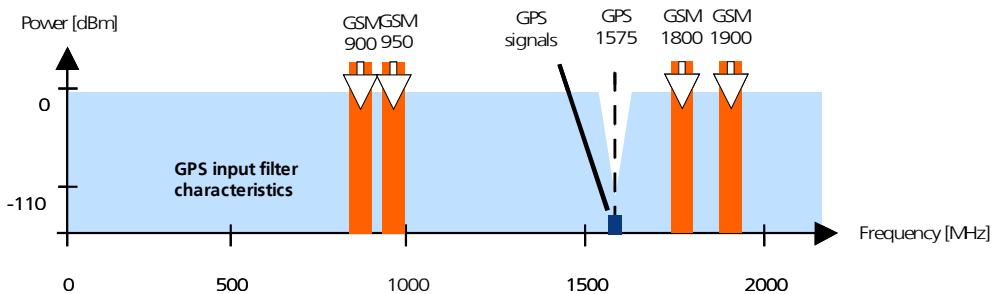

Figure 10: Out-band interference signals

Measures against out-band interference include maintaining a good grounding concept in the design and adding a SAW or bandpass ceramic filter (as recommend in section 2.14.5) into the antenna input line to the GNSS receiver (see Figure 11).

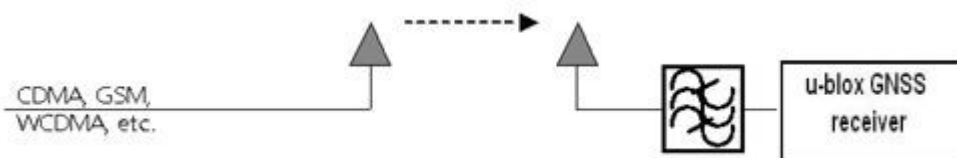

Figure 11: Measures against out-band interference

3 Product handling & soldering

3.1 Packaging, shipping, storage and moisture preconditioning

For information pertaining to reels and tapes, Moisture Sensitivity levels (MSD), shipment and storage information, as well as drying for preconditioning see the *EVA-M8M Data Sheet* [1].

3.2 ESD handling precautions

ESD prevention is based on establishing an Electrostatic Protective Area (EPA). The EPA can be a small working station or a large manufacturing area. The main principle of an EPA is that there are no highly charging materials in the vicinity of ESD sensitive electronics, all conductive materials are grounded, workers are grounded, and charge build-up on ESD sensitive electronics is prevented. International standards are used to define typical EPA and can be obtained for example from International Electrotechnical Commission (IEC) or American National Standards Institute (ANSI).

GNSS receivers are sensitive to ESD and require special precautions when handling. Particular care must be exercised when handling patch antennas, due to the risk of electrostatic charges. In addition to standard ESD safety practices, the following measures should be taken into account whenever handling the receiver.

- Unless there is a galvanic coupling between the local GND (i.e. the work table) and the PCB GND, then the first point of contact when handling the PCB shall always be between the local GND and PCB GND.
- Before mounting an antenna patch, connect ground of the device.
- When handling the RF pin, do not come into contact with any charged capacitors and be careful when contacting materials that can develop charges (e.g. patch antenna ~10 pF, coax cable ~50-80 pF/m, soldering iron, ...)
- To prevent electrostatic discharge through the RF input, do not touch the mounted patch antenna.
- When soldering RF connectors and patch antennas to the receiver's RF pin, make sure to use an ESD safe soldering iron (tip).

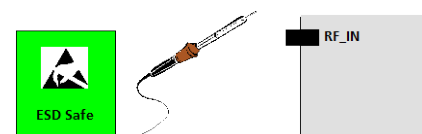
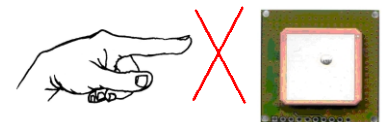
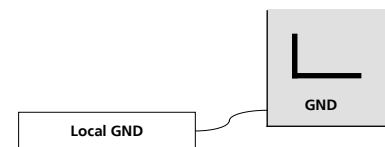

Failure to observe these precautions can result in severe damage to the GNSS receiver!

3.3 Soldering

3.3.1 Soldering paste

Use of "No Clean" soldering paste is strongly recommended, as it does not require cleaning after the soldering process has taken place.

Stencil Thickness: 100 to 150 μm for base boards

The paste-mask geometry for applying soldering paste should meet the recommendations given in section 2.11.2.

3.3.2 Reflow soldering

Preheat/ Soak Temperature min.	T_{smin}	150°C
Preheat/ Soak Temperature max.	T_{smax}	180°C
Preheat/ Soak Time from T_{smin} to T_{smax}	T_s (T_{smin} to T_{smax})	< 90 seconds
Liquidus Temperature	T_L	217°C
Time maintained above T_L	t_L	40 to 60 seconds
Peak Package Body Temperature	T_p	250°C
Ramp up rate (T_L to T_p)		3°C/ second max.
Time within +0°C...-5°C of T_p		30 seconds
Ramp down rate (T_p to T_L)		4°C/ second max.

Table 7: Recommended conditions for reflow process

The peak temperature must not exceed 250°C. The time above 245°C must not exceed 30 seconds.



EVA-M8M **must not** be soldered with a damp heat process.

3.3.3 Optical inspection

After soldering the EVA-M8M modules, consider an optical inspection step to check whether:

- The module is properly aligned and centered over the pads

3.3.4 Repeated reflow soldering

Only single reflow soldering processes are recommended for boards populated with EVA-M8M modules.

3.3.5 Wave soldering

Base boards with combined through-hole technology (THT) components and surface-mount technology (SMT) devices require wave soldering to solder the THT components. Only a single wave soldering process is encouraged for boards populated with EVA-M8M.

3.3.6 Rework

Not recommended.

3.3.7 Conformal coating

Certain applications employ a conformal coating of the PCB using HumiSeal® or other related coating products.



Conformal Coating of the module will void the warranty.

3.3.8 Casting

If casting is required, use viscose or another type of silicon pottant. The OEM is strongly advised to qualify such processes in combination with the EVA-M8M modules before implementing this in the production.



Casting will void the warranty.

3.3.9 Use of ultrasonic processes

Some components on the EVA-M8M modules are sensitive to Ultrasonic Waves. Use of any Ultrasonic Processes (cleaning, welding etc.) may cause damage to the GNSS Receiver.



u-blox offers no warranty against damages to the EVA-M8M modules caused by any Ultrasonic Processes.

4 Product testing

4.1 Test parameters for OEM manufacturer

Because of the testing done by u-blox, it is obvious that an OEM manufacturer doesn't need to repeat firmware tests or measurements of the GNSS parameters/characteristics (e.g. TTFF) in their production test.

An OEM manufacturer should focus on:

- Overall sensitivity of the device (including antenna, if applicable)
- Communication to a host controller

4.2 System sensitivity test

The best way to test the sensitivity of a GNSS device is with the use of a Multi-GNSS generator. It assures reliable and constant signals at every measurement.

u-blox recommends the following Multi-GNSS generator:

- Spirent GSS6300
Spirent Communications Positioning Technology
www.positioningtechnology.co.uk



Figure 12: Multi-GNSS generator

4.2.1 Guidelines for sensitivity tests

1. Connect a Multi-GNSS generator to the OEM product.
2. Choose the power level in a way that the "Golden Device" would report a C/No ratio of 38-40 dBHz.
3. Power up the DUT (Device Under Test) and allow enough time for the acquisition.
4. Read the C/N0 value from the NMEA GSV or the UBX-NAV-SVINFO message (e.g. with u-center).
5. Compare the results to a "Golden Device" or the u-blox EVK-M8EVA Evaluation Kit.

4.2.2 'Go/No go' tests for integrated devices

The best test is to bring the device to an outdoor position **with excellent sky view** (HDOP < 3.0). Let the receiver acquire satellites and compare the signal strength with a "Golden Device".



As the electro-magnetic field of a redistribution antenna is not homogenous, indoor tests are in most cases not reliable. These kind of tests may be useful as a 'go/no go' test but not for sensitivity measurements.

Appendix

A Reference schematics

A.1 Cost optimized circuit

- Passive Antenna
- No RTC crystal
- No backup battery
- UART and DDC for communication to host

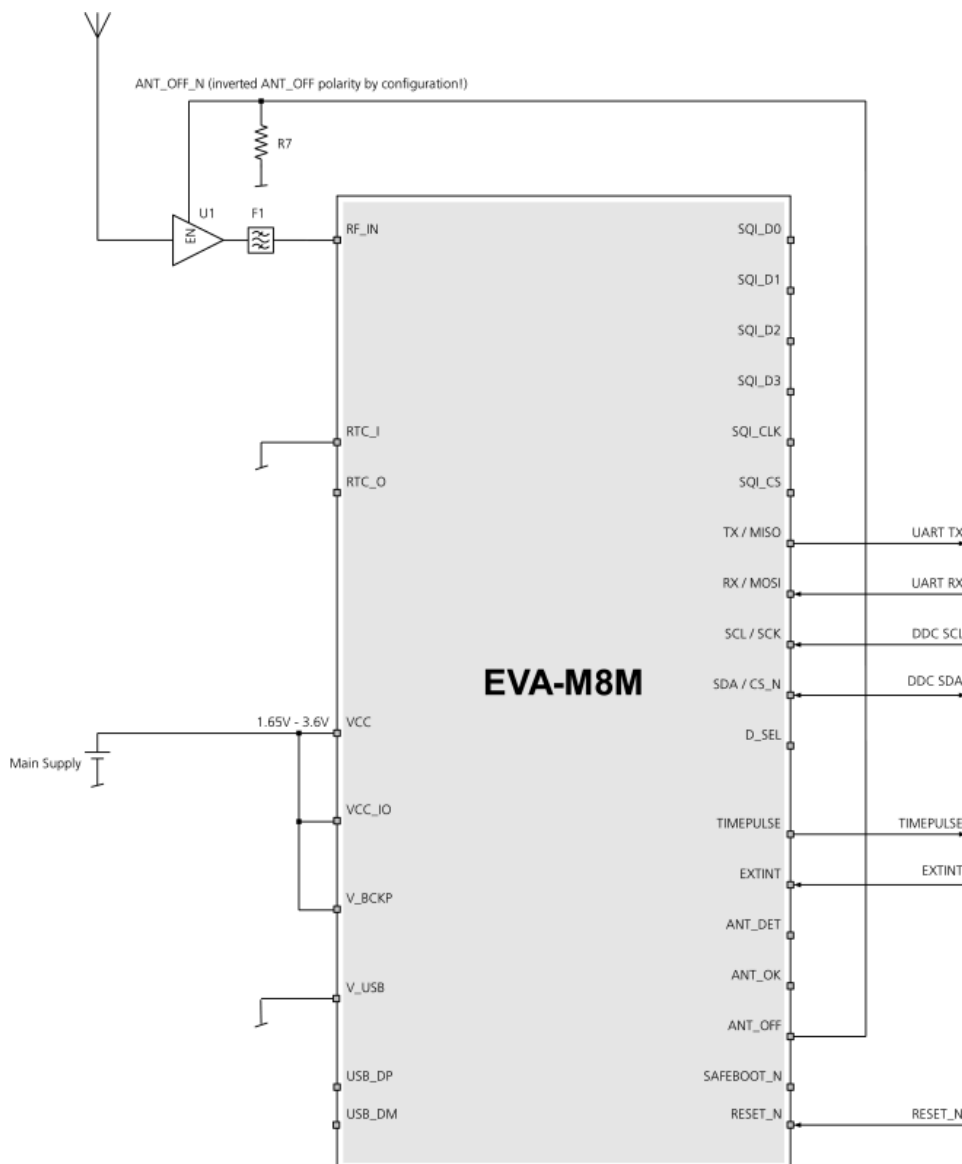

Figure 13: Cost optimized circuit

A.2 Best performance circuit with passive antenna

- External LNA
- RTC crystal
- Backup battery
- UART and DDC for communication to host

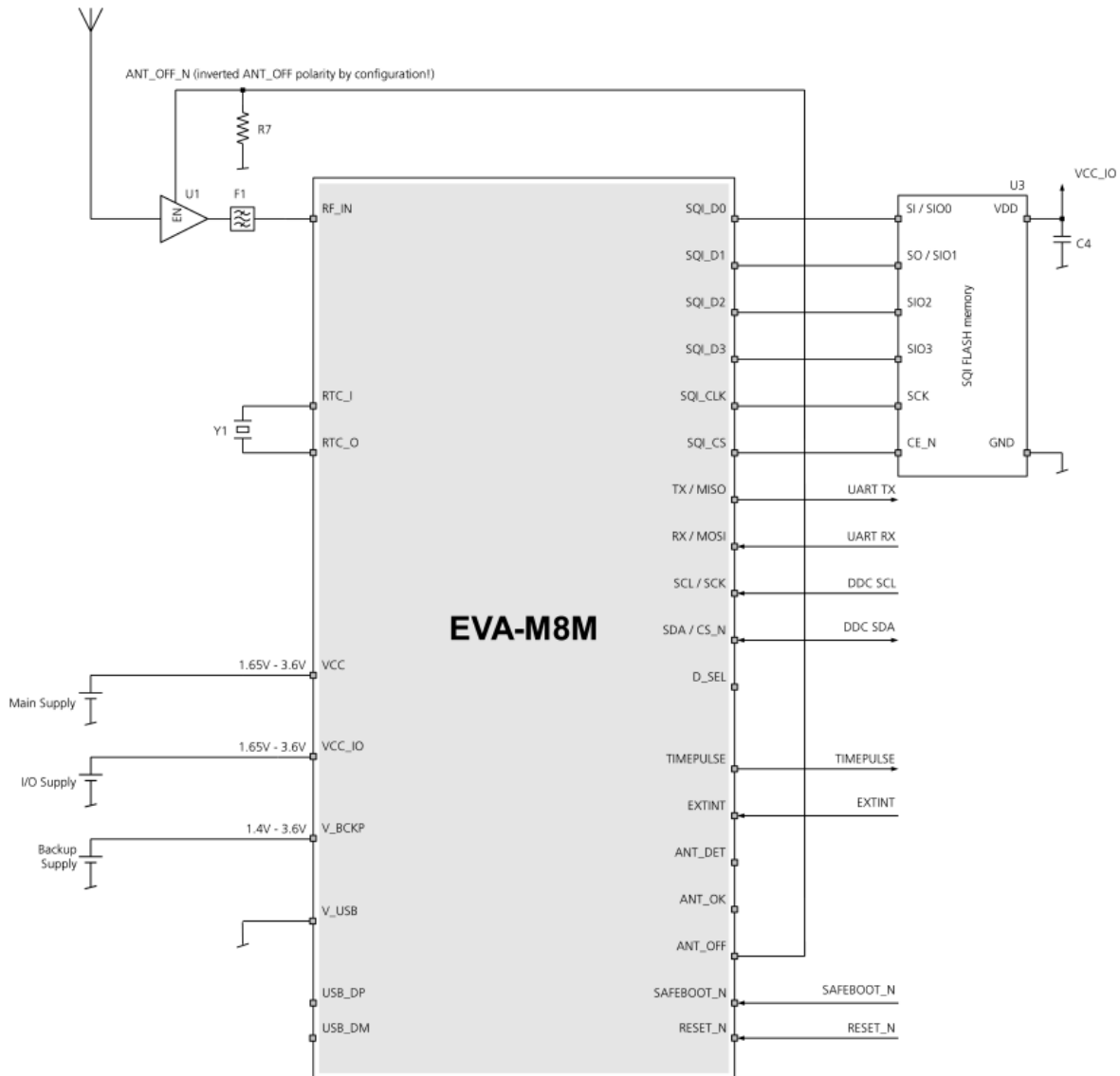

Figure 14: Best performance circuit

A.3 Improved jamming immunity with passive antenna

- External SAW filter – LNA – SAW filter
- RTC crystal
- Backup battery
- UART and DDC for communication to host

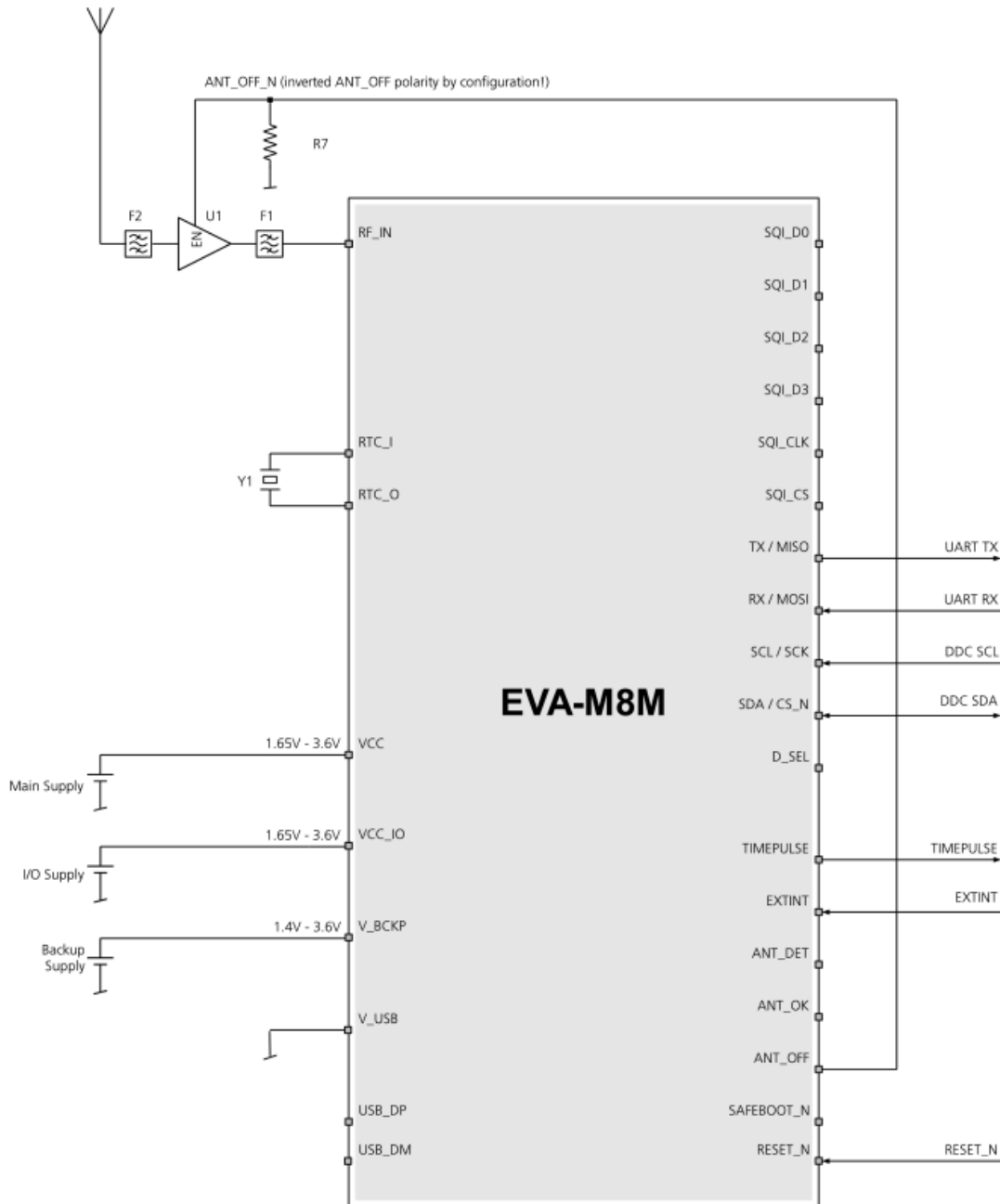

Figure 15: Standard circuit for an improved jamming immunity

A.4 Circuit using active antenna

- Active antenna
- RTC crystal
- Backup battery
- UART and DDC for communication to host

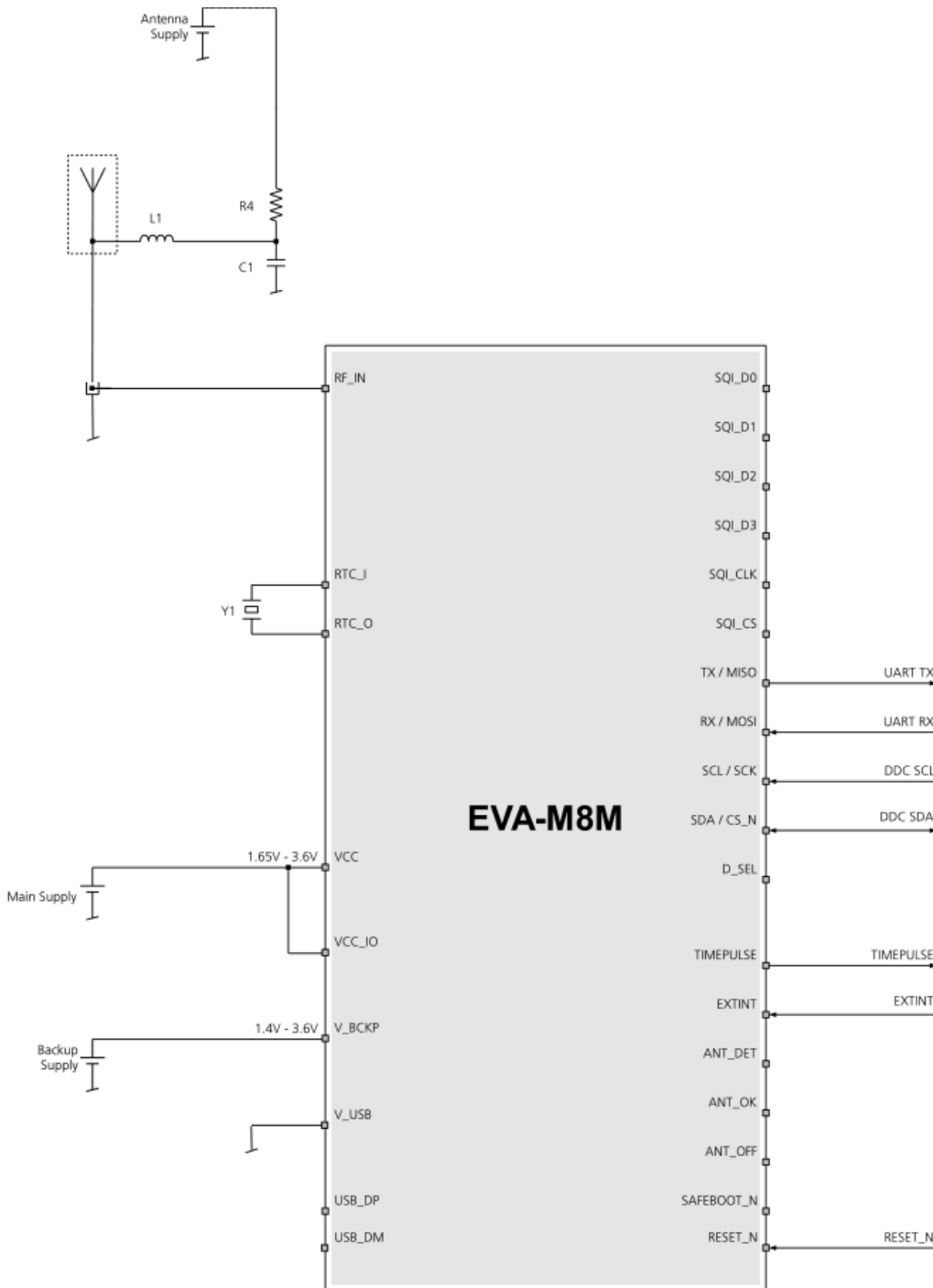

Figure 16: Standard circuit using active antenna

A.5 USB self-powered circuit with passive antenna

- External LNA
- RTC crystal
- Backup battery
- UART and DDC for communication to host
- USB interface

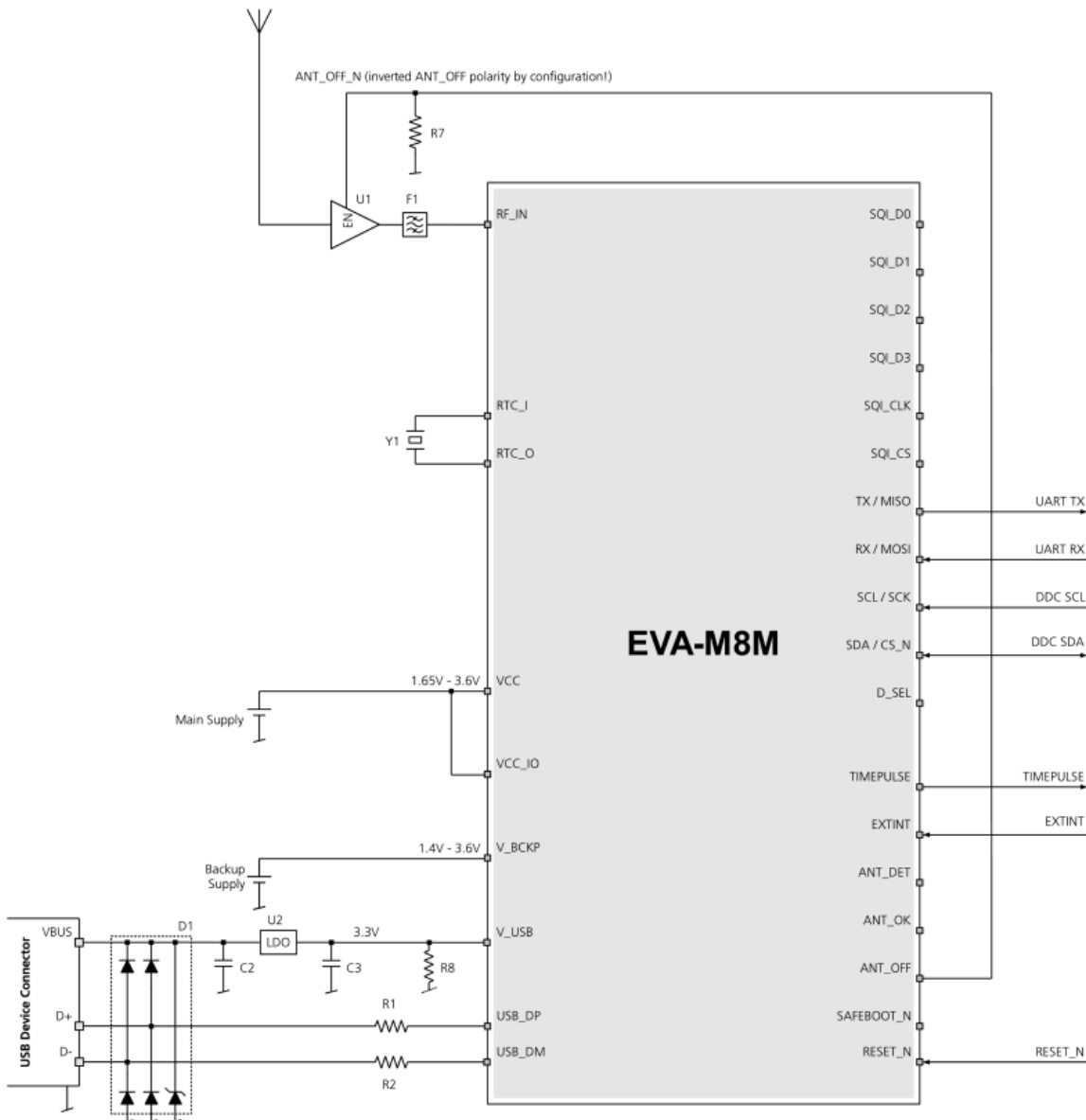

Figure 17: USB self-powered circuit

A.6 USB bus-powered circuit with passive antenna

- External LNA
- RTC crystal
- Backup battery
- SPI for communication to host
- USB interface

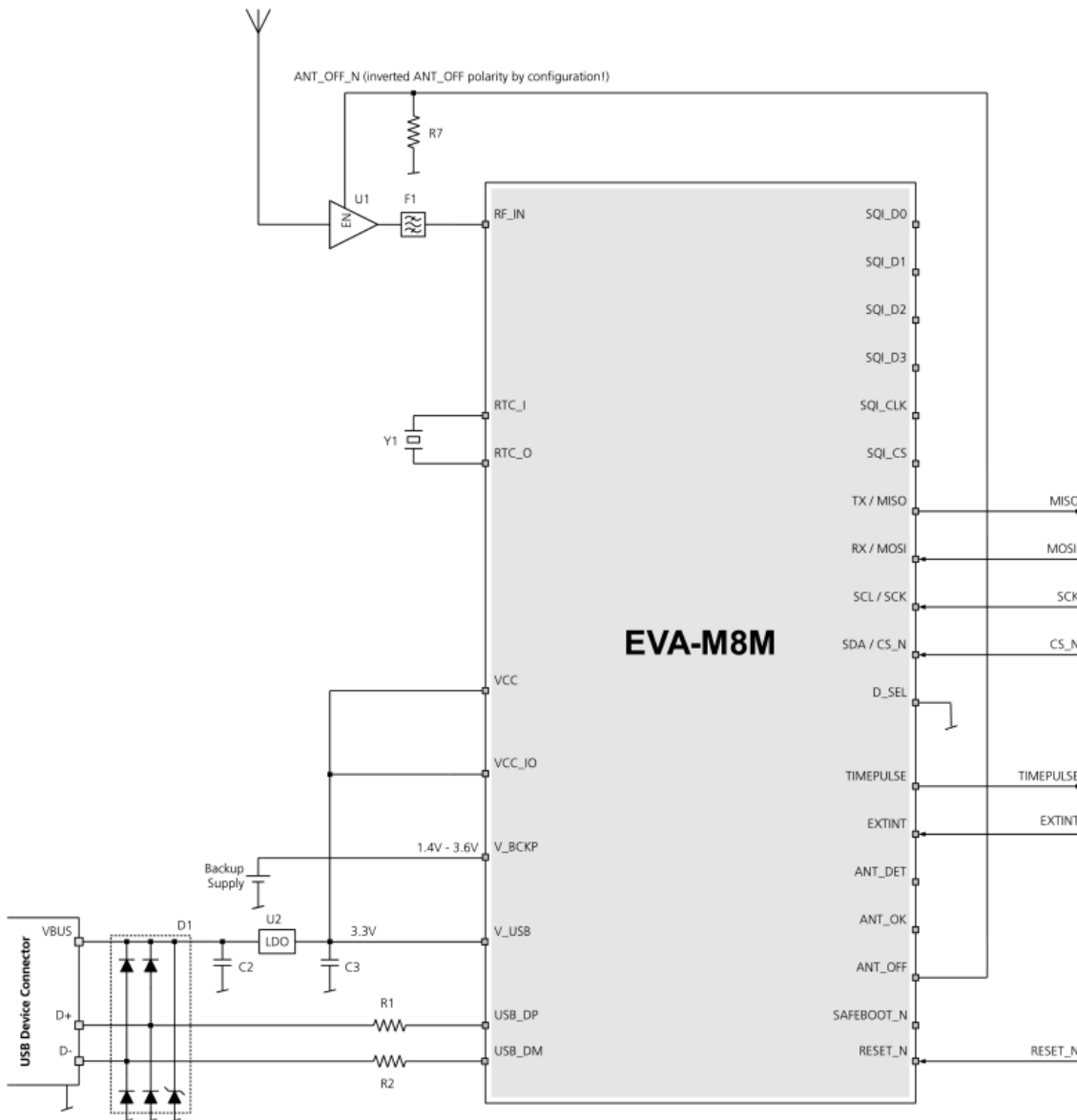

Figure 18: USB bus-powered circuit

A.7 Circuit using 2-pin antenna supervisor

- 2-pin antenna supervisor
- RTC crystal
- Backup battery
- UART and DDC for communication to host

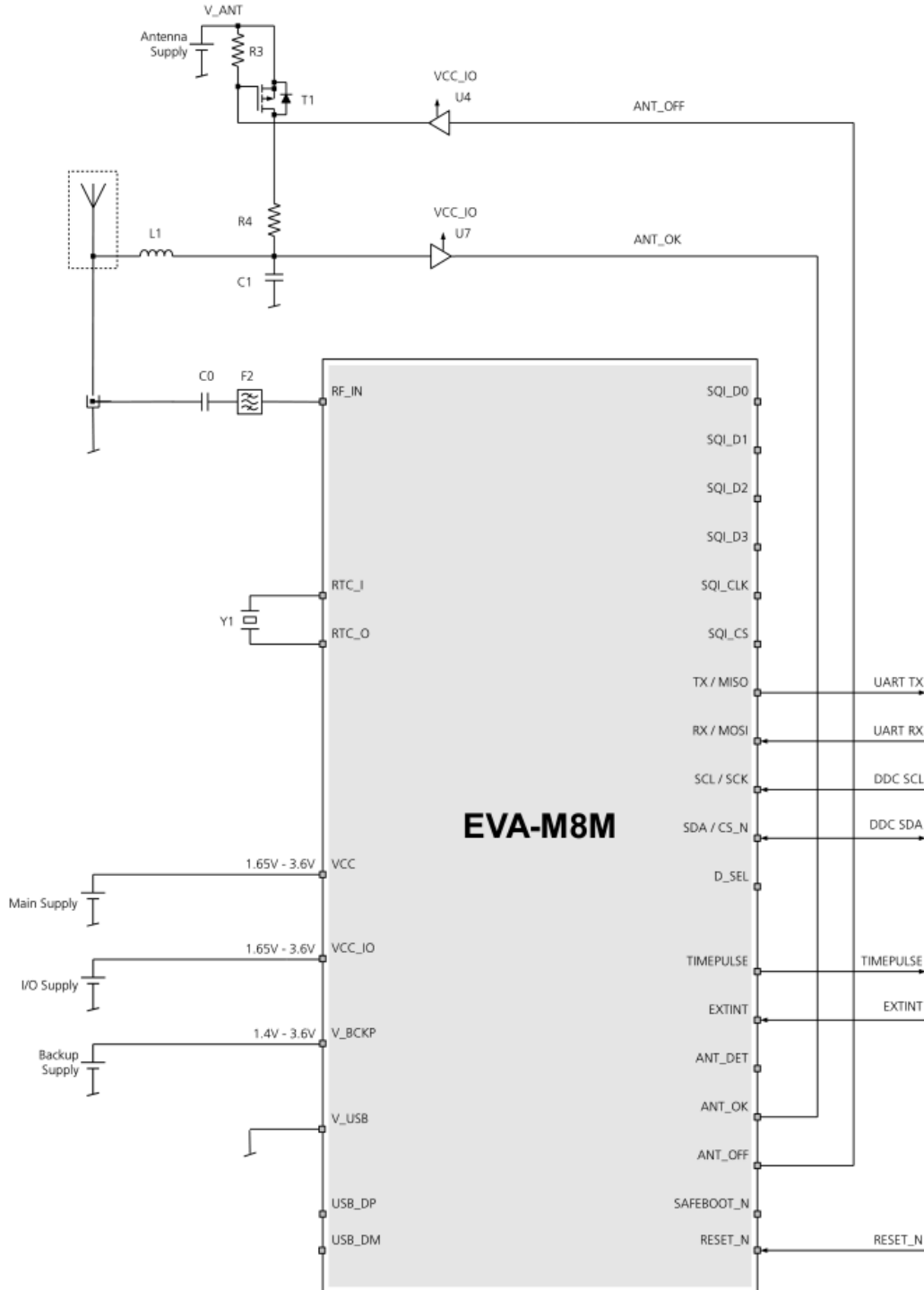

Figure 19: Circuit using 2-pin antenna supervisor

A.8 Circuit using 3-pin antenna supervisor

- 3-pin antenna supervisor
- RTC crystal
- Backup battery
- UART and DDC for communication to host

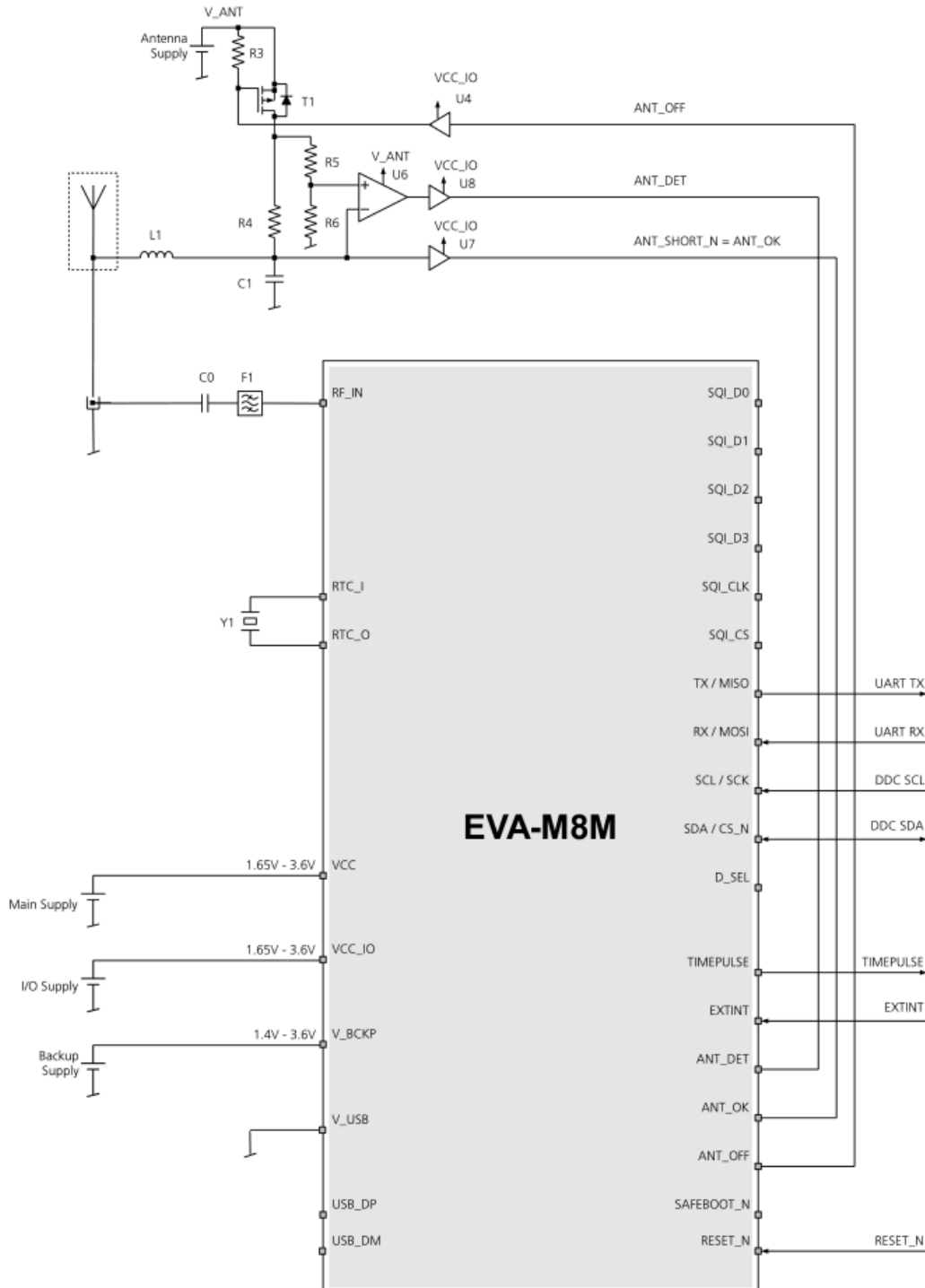







Figure 20: Circuit using 3-pin antenna supervisor

A.9 Design-in Recommendations in combination with cellular operation

Product		Receiver Chain					Cellular and GNSS Simultaneous operation			
Family	Variant						Passive GNSS Antenna		Active GNSS Antenna	
		Antenna	SAW LNA	SAW	On-chip LNA	SAW	2G cellular	3G/4G cellular	2G/3G/4G cellular	
MAX-6	Any				•	•	✓		✓	✓
NEO-6	Any				•	•	✓		✓	✓
LEA-6	Any				•	•	✓		✓	✓
EVA-7	M				•		✓		✓	✓
MAX-7	C				•		✓		✓	✓
	W				•		✓		✓	✓
	Q				•		✓		✓	✓
NEO-7	N		•		•		✓	✓	✓	✓
	M				•		✓		✓	✓
	P			•	•		✓	✓	✓	✓
EVA-M8	M				•		✓		✓	✓
MAX-M8	C				•		✓		✓	✓
	W				•		✓		✓	✓
	Q				•		✓		✓	✓
NEO-M8	N		•		•		✓	✓	✓	✓
	M				•		✓		✓	✓
	Q		•		•		✓	✓	✓	✓
LEA-M8	S		•	•	•		✓	✓	✓	✓
PAM-7	Q	•	•	•	•		✓	✓	✓	✓
CAM-M8	Q	•	•		•		✓	✓	✓	✓

• = integrated

✓ = optimal performance

Table 8: Combinations of u-blox GNSS modules with different cellular technologies (2G/3G/4G)



See the *GPS Implementation and Aiding Features in u-blox wireless modules* [5].

B Component selection

This section provides information about components that are critical for the performance of the EVA-M8M GNSS receiver module.

Recommended parts are selected on a data sheet basis only.

Temperature range specifications need only be as wide as required by a particular application. For the purpose of this document, specifications for industrial temperature range (-40 C ... +85 C) are provided.

B.1 External RTC (Y1)

ID	Parameter	Value
1	Frequency Specifications	
1.1	Oscillation mode	Fundamental Mode
1.2	Nominal frequency at 25 °C	32.768 kHz
1.3	Frequency calibration tolerance at 25 °C	< ±100 ppm
2	Electrical specifications	
2.1	Load capacitance C_L	7 pF
2.2	Equivalent series resistance R_s	< 100 kΩ

Table 9: RTC crystal specifications

Manufacturer	Order No.
Micro Crystal	CC7V-T1A 32.768 kHz 7.0 pF +/- 100 ppm

Table 10: Recommend parts list for RTC crystal

B.2 RF band-pass filter (F1)

Depending on the application circuit, consult manufacturer data sheet for DC, ESD and RF power ratings!

Manufacturer	Order No.	System supported	Comments
TDK/ EPCOS	B8401: B39162B8401P810	GPS+GLONASS	High attenuation
TDK/ EPCOS	B3913: B39162B3913U410	GPS+GLONASS+BeiDou	For automotive application
TDK/ EPCOS	B9416: B39162B9416K610	GPS	High input power
TDK/ EPCOS	B4310: B39162B4310P810	GPS+GLONASS	Compliant to the AEC-Q200 standard
TDK/ EPCOS	B4327: B39162B4327P810	GPS+GLONASS+BeiDou	Low insertion loss
TDK/ EPCOS	B9482: B39162B9482P810	GPS+GLONASS	Low insertion loss
muRata	SAFFB1G56KB0F0A	GPS+GLONASS+BeiDou	Low insertion loss, Only for mobile application
muRata	SAFEA1G58KA0F00	GPS+GLONASS	Only for mobile application
muRata	SAFFB1G58KA0F0A	GPS+GLONASS	Only for mobile application
Triquint	856561	GPS	Compliant to the AEC-Q200 standard
TAI-SAW	TA1573A	GPS+GLONASS	Low insertion loss
TAI-SAW	TA1343A	GPS+GLONASS+BeiDou	Low insertion loss

Table 11: Recommend parts list for RF band-pass filter

B.3 External LNA protection filter (F2)

Depending on the application circuit, consult manufacturer data sheet for DC, ESD and RF power ratings!

Manufacturer	Order No.	System supported	Comments
TDK/ EPCOS	B8401: B39162-B8401-P810	GPS+GLONASS	High attenuation
TDK/ EPCOS	B3913: B39162B3913U410	GPS+GLONASS+BeiDou	For automotive application
TDK/ EPCOS	B4310: B39162B4310P810	GPS+GLONASS	Compliant to the AEC-Q200 standard
TDK/ EPCOS	B4327: B39162B4327P810	GPS+GLONASS+BeiDou	Low insertion loss
TDK/ EPCOS	B9850: B39162B9850P810	GPS	Low insertion loss
TDK/ EPCOS	B8400: B39162B8400P810	GPS	ESD protected and high input power
TDK/ EPCOS	B9416: B39162B9416K610	GPS	High input power
muRata	SAFFB1G56KB0F0A	GPS+GLONASS+BeiDou	Low insertion loss, Only for mobile application
muRata	SAFEA1G58KB0F00	GPS+GLONASS	Low insertion loss, only for mobile application
muRata	SAFEA1G58KA0F00	GPS+GLONASS	High attenuation, only for mobile application
muRata	SAFFB1G58KA0F0A	GPS+GLONASS	High attenuation, only for mobile application
muRata	SAFFB1G58KB0F0A	GPS+GLONASS	Low insertion loss, Only for mobile application
Triquint	B9850	GPS	Compliant to the AEC-Q200 standard
CTS	CER0032A	GPS	Ceramic filter also offers robust ESD Protection
TAI-SAW	TA1573A	GPS+GLONASS	Low insertion loss
TAI-SAW	TA1343A	GPS+GLONASS+BeiDou	Low insertion loss

Table 12: Recommended parts for the LNA protection filter

B.4 USB line protection (D1)

Manufacturer	Order No.
ST Microelectronics	USBLC6-2

Table 13: Recommend parts list for USB line protection

B.5 USB LDO (U2)

Manufacturer	Order No.
Seiko Instruments Inc.	S-1206B33-I6T2G

Table 14: Recommend parts list for USB LDO

B.6 External LNA (U1)

ID	Parameter	Value
1	Gain and Noise Figure @ 1.575 GHz	
1.1	Gain	> 17 dB
1.2	Noise Figure	< 2 dB

Table 15: External LNA specifications

Manufacturer	Order No.	Comments
Maxim	MAX2659ELT+	Low noise figure, up to 10 dBm RF input power
JRC New Japan Radio	NJG1143UA2	Low noise figure, up to 15 dBm RF input power
NXP	BGU8006	Low noise figure, small size
Avago	ALM-GN001	Low noise figure, with pre-LNA filter, concurrent GNSS
Avago	ALM-GN002	Low noise figure, with post-LNA filter, concurrent GNSS

Table 16: Recommend parts list for external LNA

B.7 Optional SQI Flash (U3)

Manufacturer	Order No.	Comments
Macronix	MX25U8035E	1.8V, 8Mbit, several package/temperature options
Macronix	MX25U1635E	1.8V, 16Mbit, several package/temperature options
Macronix	MX25L3239E	3V, 32Mbit, several package/temperature options
Spansion	S25FL116K	3V, 16Mbit, several package/temperature options
Spansion	S25FL132K	3V, 32Mbit, several package/temperature options
Winbond	W25Q16DW	1.8V, 16Mbit, several package/temperature options
Winbond	W25Q80BV	3V, 8Mbit, several package/temperature options
Winbond	W25Q80DV	3V, 8Mbit, several package/temperature options
Winbond	W25Q16DV	3V, 16Mbit, several package/temperature options
Winbond	W25Q32BV	3V, 32Mbit, several package/temperature options
Winbond	W25Q32DW	1.8V, 32Mbit, several package/temperature options

Table 17: Recommend parts list for optional SQI Flash

B.8 RF ESD protection diode (D2)

Manufacturer	Order No.
ON Semiconductor	ESD9R3.3ST5G
Infineon	ESD5V3U1U-02LS

Table 18: Recommend parts list for RF ESD protection diode

B.9 Operational amplifier (U6)

Manufacturer	Order No.
Linear Technology	LT6000
Linear Technology	LT6003

Table 19: Recommend parts list for Operational Amplifier

B.10 Open-drain buffer (U4, U7 and U8)

Manufacturer	Order No.
Fairchild	NC7WZ07P6X

Table 20: Recommend parts list for open-drain buffer

B.11 Antenna supervisor switch transistor (T1)

Manufacturer	Order No.
Vishay	Si1016X-T1-E3 (p-channel)

Table 21: Recommend parts list for antenna supervisor switch transistor (p-channel MOSFET)

B.12 Ferrite beads (FB1)

Manufacturer	Order No.	Comments
MuRata	BLM15HD102SN1	High impedance @ 1.575 GHz
MuRata	BLM15HD182SN1	High impedance @ 1.575 GHz
TDK	MMZ1005F121E	High impedance @ 1.575 GHz
TDK	MMZ1005A121E	High impedance @ 1.575 GHz

Table 22: Recommend parts list for ferrite beads FB1

B.13 Feed-thru capacitors

Manufacturer	Order No.	Comments
MuRata	NFL18SP157X1A3	For data signals, 34 pF load capacitance
MuRata	NFA18SL307V1A45	For data signals, 4 circuits in 1 package
MuRata	NFM18PC474R0J3	For power supply < 2 A, size 0603
MuRata	NFM21PC474R1C3	For power supply < 4 A, size 0805

Table 23: Recommend parts list for feed thru capacitors

B.14 Inductor (L)

Manufacturer	Order No.
MuRata	LQG15H Series
MuRata	LQP15M Series
MuRata	LQW15A Series
Johanson Technology	L-07W Series

Table 24: Recommend parts list for inductor

B.15 Standard capacitors

Name	Use	Type / Value
C0	RF-input DC block	COG 47P 5% 25V
C1	Decoupling Capacitor	X7R 10N 10% 16V
C2	Decoupling capacitor at VBUS	Depends on USB LDO (U2) specification
C3	Decoupling capacitor at VBUS	Depends on USB LDO (U2) specification
C4	Decoupling VCC_IO at SQI Flash supply pin	X5R 1U0 10% 6.3V

Table 25: Standard capacitors

B.16 Standard resistors

Name	Use	Type / Value
R1	USB data serial termination	27R 5% 0.1W
R2	USB data serial termination	27R 5% 0.1W
R3	Pull-up at antenna supervisor transistor	100K 5% 0.1W
R4	Antenna supervisor current limiter	10R 5% 0.25W
R5	Antenna supervisor voltage divider	560R 5% 0.1W
R6	Antenna supervisor voltage divider	100K 5% 0.1W
R7	Pull-up at LNA enable	10K 5% 0.1W
R8	Pull-down at V_USB	100K 5% 0.1W

Table 26: Standard resistors

Appendix

C Glossary

Abbreviation	Definition
ANSI	American National Standards Institute
BeiDou	Chinese satellite navigation system
CDMA	Code Division Multiple Access
EMI	Electromagnetic interference
EOS	Electrical Overstress
EPA	Electrostatic Protective Area
ESD	Electrostatic discharge
GLONASS	Russian satellite system
GND	Ground
GNSS	Global Navigation Satellite System
GPS	Global Positioning System
GSM	Global System for Mobile Communications
IEC	International Electrotechnical Commission
PCB	Printed circuit board
SBAS	Satellite-Based Augmentation System
QZSS	Quasi-Zenith Satellite System
WCDMA	Wideband Code Division Multiple Access

Table 27: Explanation of abbreviations used

Related documents

- [1] EVA-M8M Data Sheet, Docu. No. UBX-14015058
- [2] u-blox M8 Receiver Description Including Protocol Specification (Public version), Docu. No. UBX-13003221
- [3] GPS Antenna Application Note, Docu. No. GPS-X-08014
- [4] GPS Compendium, Docu. No. GPS-X-02007
- [5] GPS Implementation and Aiding Features in u-blox wireless modules, Docu. No. GSM.G1-CS-09007
- [6] u-blox 7 to u-blox M8 Software Migration Guide, Docu. No. UBX-13003254



For regular updates to u-blox documentation and to receive product change notifications please register on our homepage.

Revision history

Revision	Date	Name	Status / Comments
R01	30-Sep-2014	julu/ffel	Advance Information
R02	09-Dec-2014	julu	Early Production Information. Updated Table 16 (Avago external LNA), updated Table 17 (removed 4 Mbit component from the recommended optional SQI Flash).

Contact

For complete contact information, visit us at www.u-blox.com

u-blox Offices

North, Central and South America

u-blox America, Inc.

Phone: +1 703 483 3180
E-mail: info_us@u-blox.com

Regional Office West Coast:

Phone: +1 408 573 3640
E-mail: info_us@u-blox.com

Technical Support:

Phone: +1 703 483 3185
E-mail: support_us@u-blox.com

Headquarters Europe, Middle East, Africa

u-blox AG

Phone: +41 44 722 74 44
E-mail: info@u-blox.com
Support: support@u-blox.com

Asia, Australia, Pacific

u-blox Singapore Pte. Ltd.

Phone: +65 6734 3811
E-mail: info_ap@u-blox.com
Support: support_ap@u-blox.com

Regional Office Australia:

Phone: +61 2 8448 2016
E-mail: info_anz@u-blox.com
Support: support_ap@u-blox.com

Regional Office China (Beijing):

Phone: +86 10 68 133 545
E-mail: info_cn@u-blox.com
Support: support_cn@u-blox.com

Regional Office China (Shenzhen):

Phone: +86 755 8627 1083
E-mail: info_cn@u-blox.com
Support: support_cn@u-blox.com

Regional Office India:

Phone: +91 959 1302 450
E-mail: info_in@u-blox.com
Support: support_in@u-blox.com

Regional Office Japan:

Phone: +81 3 5775 3850
E-mail: info_jp@u-blox.com
Support: support_jp@u-blox.com

Regional Office Korea:

Phone: +82 2 542 0861
E-mail: info_kr@u-blox.com
Support: support_kr@u-blox.com

Regional Office Taiwan:

Phone: +886 2 2657 1090
E-mail: info_tw@u-blox.com
Support: support_tw@u-blox.com