



MICROCHIP

BLEDK3 Command Set (v1.20)

Contents

1	General description	7
2	MCU interface.....	7
2.1	PIN definition	7
2.2	UART Protocol.....	7
2.3	UART configuration.....	8
2.4	UART data exchange for low power mode	8
2.5	UART flow control.....	9
2.6	UART packet error handle	10
3	Command opcode definition.....	11
3.1	Rules of MCU Command Assign	13
3.2	Common_1 commands.....	15
3.2.1	Read_Local_Information (0x01).....	15
3.2.2	Reset (0x02)	16
3.2.3	Read_BLEDK3_Status (0x03)	16
3.2.4	Read_ADC_Value (0x04)	17
3.2.5	Into_Shutdown_Mode (0x05).....	18
3.2.6	Debug_Command (0x06).....	19
3.2.7	Read_Device_Name (0x07).....	20
3.2.8	Write_Device_Name (0x08).....	21
3.2.9	Erase_All_Paired_Device_Information (0x09)	22
3.2.10	Read_Pairing_Mode_Setting (0x0A)	23
3.2.11	Write_Pairing_Mode_Setting (0x0B).....	24
3.2.12	Read_All_Paired_Device_Information (0x0C)	25
3.2.13	Delete_Paired_Device (0x0D)	26
3.2.14	DIO_Control (0x0E)	27
3.2.15	PWM_Control (0x0F)	29
3.3	GAP Commands.....	31

BLEDK3 Command Set

3.3.1	Read_RSSI_Value (0x10)	31
3.3.2	Write_Adv_Data (0x11)	32
3.3.3	Write_Scan_Res_Data (0x12)	33
3.3.4	Set_Advertising_Parameter (0x13)	34
3.3.5	Set_Scan_Parameter (0x15)	35
3.3.6	Set_Scan_Enable (0x16)	36
3.3.7	LE_Create_Connection (0x17)	37
3.3.8	LE_Create_Connection_Cancel (0x18)	38
3.3.9	Connection_Parameter_Update_Req (0x19)	38
3.3.10	Disconnect (0x1B)	39
3.3.11	Set_Adv_Enable (0x1C)	40
3.3.12	Read_Remote_Device_Name (0x1F)	41
3.4	GATT Client Commands	41
3.4.1	Discover_All_Primary_Services (0x30)	42
3.4.2	Discovre_Specific_Primary_Service_Characteristics (0x31)	42
3.4.3	Read_Characteristic_Value (0x32)	43
3.4.4	Read_Using_Characteristic_UUID (0x33)	43
3.4.5	Write_Characteristic_Value (0x34)	44
3.4.6	Enable_Transparent (0x35)	45
3.5	GATT Server Commands	45
3.5.1	Send_Characteristic_Value (0x38)	45
3.5.2	Update_Characteristic_Value (0x39)	46
3.5.3	Read_Local_Characteristic_Value (0x3A)	47
3.5.4	Read_Local_All_Primary_Service (0x3B)	47
3.5.5	Read_Local_Specific_Primary_Service (0x3C)	48
3.5.6	Send_Write_Response (0x3D)	48
3.6	GATT Transparent Command	49
3.6.1	Send_Transparent_Data (0x3F)	49

BLEDK3 Command Set

3.7	Pairing Commands	50
3.7.1	Passkey_Entry_Res (0x40)	50
3.7.2	User_Confirm_Res (0x41)	52
3.7.3	Pairing_Request (0x42)	53
3.8	Common_2_Command.....	54
3.8.1	Leave_Configure_Mode (0x52)	54
4	Event OP code definition.....	56
4.1	Pairing Event	56
4.1.1	Passkey_Entry_Req (0x60)	56
4.1.2	Pairing_Complete (0x61)	56
4.1.3	Passkey_Confirm_Req (0x62)	57
4.2	GAP Event.....	57
4.2.1	Advertising_Report (0x70)	57
4.2.2	LE_Connection_Complete (0x71).....	58
4.2.3	Disconnection_Complete (0x72).....	60
4.2.4	Connection_Parameter_Update_Notify (0x73).....	60
4.3	Common Event.....	61
4.3.1	Command_Complete (0x80).....	61
4.3.2	BLEDK3_Status_Report (0x81)	61
4.3.3	Configure_Mode_Status (0x8F).....	61
4.4	GATT Client Event.....	62
4.4.1	Discover_All_Primary_Services_Res (0x90)	62
4.4.2	Discover_Specific_Primary_Service_Characteristic_Res (0x91).....	62
4.4.3	Discover_All_Characteristic_Descriptors_Res (0x92)	63
4.4.4	Characteristic_Value_Received (0x93).....	64
4.5	GATT Server Event	65
4.5.1	Client_Write_Characteristic_Value (0x98)	65
4.6	GATT Transparent Event.....	65

BLEDK3 Command Set

4.6.1	Received_Transparent_Data (0x9a)	65
5	Operation Definition	66
5.1	Application Pattern Configuration	66
5.1.1	Auto Pattern.....	66
5.1.2	Manual Pattern	66
5.2	Mode	66
5.2.1	Scanning Mode.....	66
5.2.2	Connecting Mode	66
5.2.3	Standby Mode	67
5.2.4	Broadcast Mode	67
5.2.5	Transparent Service Enabled Mode	67
5.2.6	Idle Mode.....	67
5.2.7	Shutdown Mode.....	67
5.2.8	Configure Mode	67
5.2.9	BLE Connected Mode	68
5.3	Data Pipe.....	68
5.4	BLEDK3 State Indication in Auto Pattern	69
6	State machine charts	70
6.1	Power on Flow.....	70
6.2	Auto Pattern	71
6.3	Manual Pattern	72
7	Message sequence charts	73
7.1	Standby Mode	73
7.2	LE Connected Mode.....	74
7.2.1	Manual Pattern Send Data	74
7.2.2	Auto Pattern Send Data.....	75
7.2.3	Manual Pattern Receive Data.....	76
7.2.4	Auto Pattern Receive Data	77

BLEDK3 Command Set

- 7.3 LE Pairing Method: Passkey Entry 78
- 7.4 LE Pairing Method: Passkey Confirm 79
- 8 Listing of command status error code 80
- 9 Listing of bledk3 status 81
- 10 Revision history 81

BLEDK3 Command Set

1 GENERAL DESCRIPTION

BLEDK3 provides UART communication interface with MCU. This document describes how MCU communicates with **BLEDK3** and the behavior of **BLEDK3**.

2 MCU INTERFACE

2.1 PIN definition

Name	Type	Description	BM70 Define
UART_TXD (Mandatory)	Output		HCI_TXD
UART_RXD (Mandatory)	Input		HCI_RXD
UART_TX_IND (Optional)	Output	BLEDK3 inform Host MCU that UART data will be transmitted out after few us (Setting by UI Tool, default 5ms)	P2_7
UART_RX_IND (Optional)	Input	Host MCU inform BLEDK3 that UART data will be transmitted out after few us	Configurable
UART_RTS (Optional)	Output	UART Flow Control High: UART flow stop Low: UART flow Go	P3_6
UART_CTS (Optional)	Input	UART Flow Control High: UART flow stop Low: UART flow Go	P0_0

2.2 UART Protocol

The UART protocol is shown as below diagram

	HEAD		MID	DATA	CRC
	START	LENGTH	OP Code	PARAMETER	CHKSUM
BYTE NO	0	1 ~ 2	3	4 ~ XX	Length + 3
SIZE (BYTE)	1	2	1	0 ~	1
VALUE	0xAA	1 ~	Command/Event	Command/Event parameter	Check sum
	SINC WORD	Check sum to be calculated			
		TARGET LENGTH			

BLEDK3 Command Set

Check sum rule: Summation of every byte after START WORD(LENGTH, COM.ID, COM PARAM, CHK SUM) is 0xXX00

e.g.

	START	LENGTH(H)	LENGTH(L)	OP CODE	PARAMETER	CHKSUM
BYTE NO	0	1	2	3	4	5
VALUE	0xAA	0x00	0x02	0x01	0x00	0xFD

2.3 UART configuration

- Baud Rate Setting: 2400bps~921600bps
- Flow Control Setting: Enabled/Disabled

2.4 UART data exchange for low power mode

- Signal of UART_TX_IND and UART_RX_IND are required to guarantee the correction of UART data.

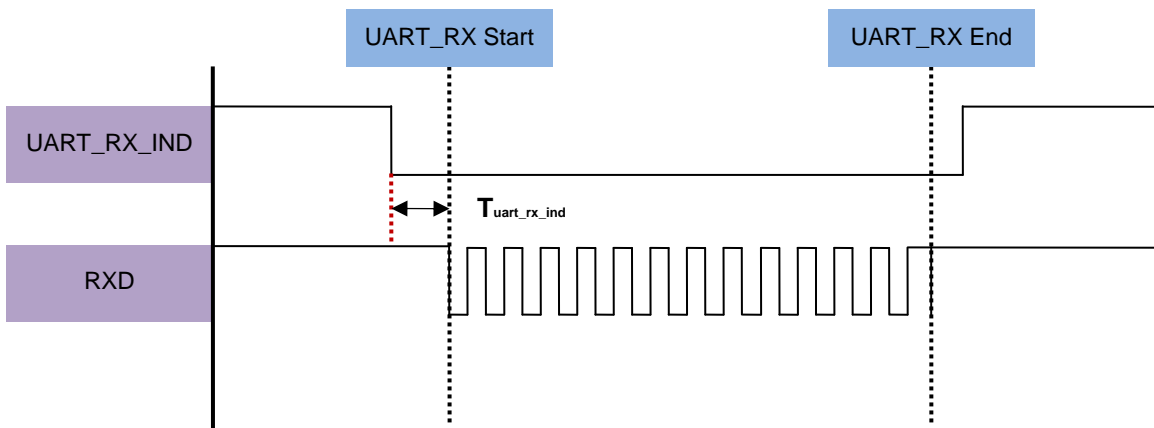

* $T_{uart_rx_ind}$: >2ms

Fig 2.4.1 Host MCU indicate BLEDK3 UART data diagram

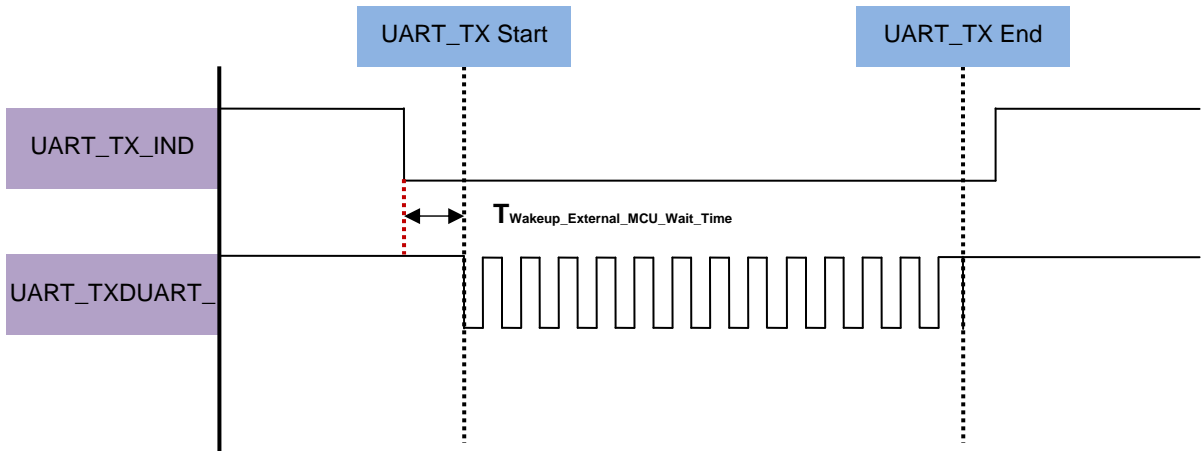

* $T_{\text{Wakeup_External_MCU_Wait_Time}}$: The time before UART TXD send (set by UI)

Fig 2.4.2 BLEDK3 indicate Host MCU UART data timing diagram

2.5 UART flow control

- CTS/RTS signal flow control scheme
- UART flow control scheme can be configured by UI setting
- If UART_CTS sets flow stop while data transmitting, **BLEDK3** will stop transmit. And it won't transmit more than two bytes after flow stop

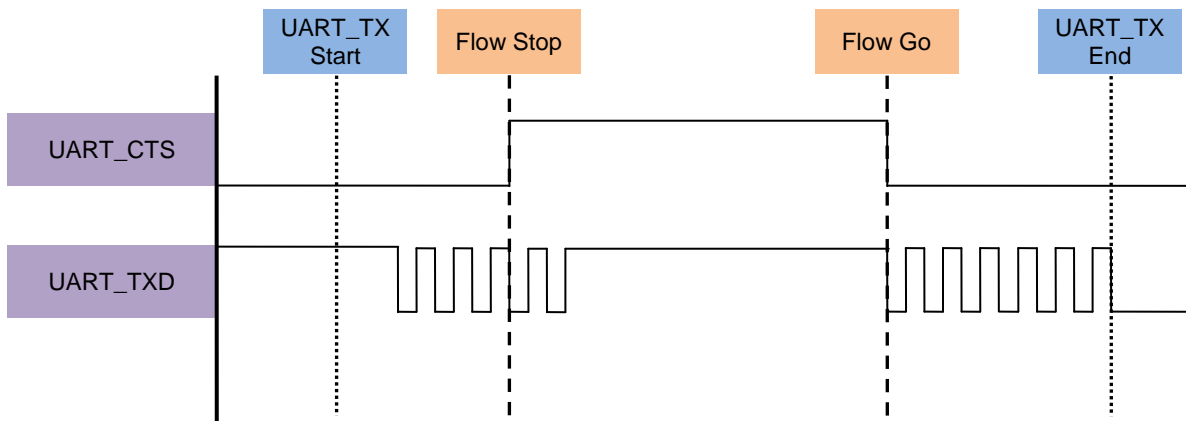

Fig 2.5.1 Host MCU indicate BLEDK3 UART flow control timing diagram

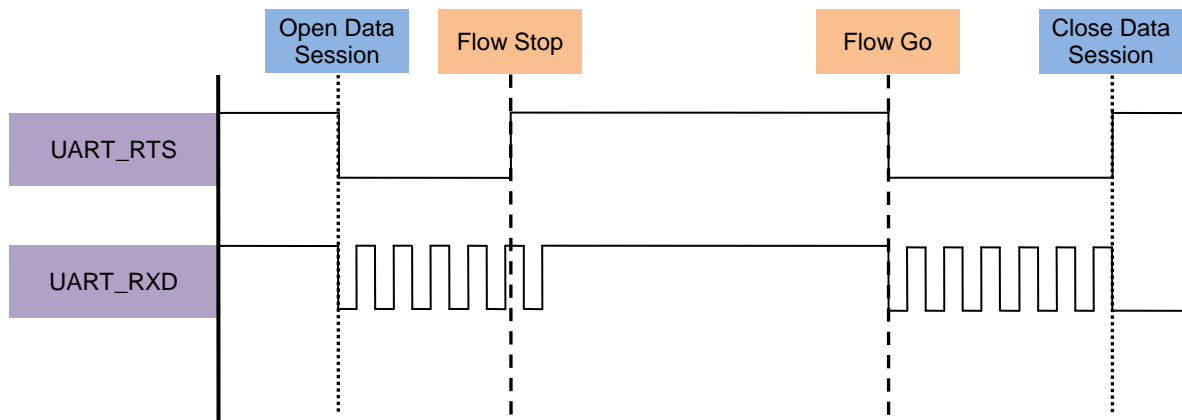

Fig 2.5.2 BLEDK3 indicate Host MCU UART flow control timing diagram

2.6 UART packet error handle

BLEDK3 will reply Command_Complete with UART_Check_Sum_Error (0xff) status if it receives UART packets with check sum error

BLEDK3 Command Set

3 COMMAND OPCODE DEFINITION

Command Type	OP code	Command	Return event	Auto pattern	Manual pattern	
Common_1	0x01	Read_Local_Information	Command_Complete	F		
	0x02	Reset	BLEDK3_Status_Report	N/A		
	0x03	Read_BLEDK3_Status	BLEDK3_Status_Report	N/A		
	0x04	Read_ADC_Value	Command_Complete	N/A		
	0x05	Into_Shutdown_Mode	Command_Complete	N/A		
	0x06	Debug_Command	Command_Complete	N/A		
	0x07	Read_Device_Name	Command_Complete	F		
	0x08	Write_Device_Name	Command_Complete	F	I	
	0x09	Erase_All_Paired_Device_Information	Command_Complete	F	I	
	0x0A	Read_Pairing_Mode_Setting	Command_Complete	F		
	0x0B	Write_Pairing_Mode_Setting	Command_Complete	F	I	
	0x0C	Read_All_Paired_Device_Information	Command_Complete	F		
	0x0D	Delete_Paired_Device	Command_Complete	F	I	
	0x0E	DIO_Control	Command_Complete	N/A		
	0x0F	PWM_Control	Command_Complete	N/A		
	GAP	0x10	Read_RSSI_Value	Command_Complete	N/A	CM
		0x11	Write_Adv_Data	Command_Complete	F	I
		0x12	Write_Scan_Res_Data	Command_Complete	F	I
		0x13	Set_Advertising_Parameter	Command_Complete	F	I
0x15		Set_Scan_Parameter	Command_Complete	N/A	I	
0x16		Set_Scan_Enable	Command_Complete Advertising_Report	N/A	I	
0x17		LE_Create_Connection	LE_Connection_Complete	N/A	I	
0x18		LE_Create_Connection_Cancel	Command_Complete LE_Connection_Complete	N/A		
0x19		Connection_Parameter_Update_Req	Command_Complete Connection_Parameter_Update_Notify	N/A	CM	
0x1B		Disconnect	Disconnection_Complete	N/A	CM	
0x1C		Set_Adv_Enable	Command_Complete	N/A	I	
0x1F	Read_Remote_Device_Name	Command_Complete	N/A	CM		
GATT Client	0x30	Discover_All_Primary_Services	Discover_All_Primary_Services_Res	N/A	CM	
	0x31	Discover_Specific_Primary_Service_Characteristics	Command_Complete Discover_Specific_Primary_Service_Characteristic_R	N/A	CM	

BLEDK3 Command Set

			es		
			Discover_All_Characteristic_Descriptors_Res		
	0x32	Read_Characteristic_Value	Command_Complete	N/A	CM
	0x33	Read_Using_Characteristic_UID	Command_Complete	N/A	CM
	0x34	Write_Characteristic_Value	Command_Complete	N/A	CM
	0x35	Enable_Transparent	Command_Complete	N/A	CM
GATT Server	0x38	Send_Characteristic_Value	Command_Complete	N/A	CM
	0x39	Update_Characteristic_Value	Command_Complete	N/A	
	0x3A	Read_Local_Characteristic_Value	Command_Complete	N/A	
	0x3B	Read_Local_All_Primary_Service	Command_Complete Discover_All_Primary_Services_Res	N/A	
	0x3C	Read_Local_Specific_Primary_Service	Command_Complete Discover_Specific_Primary_Service_Characteristics Discover_All_Characteristic_Descriptors_Res	N/A	
	0x3D	Send_Write_Response	Command_Complete	N/A	CM
GATT Transparent	0x3F	Send_Transparent_Data	Command_Complete	N/A	CM
Pairing	0x40	Passkey_Entry_Res	Command_Complete	CP	CP
	0x41	User_Confirm_Res	Command_Complete	CP	CP
	0x42	Pairing_Request	Command_Complete	N/A	CM
Common_2	0x52	Leave_Configure_Mode	Command_Complete	F	N/A

*I: Available in Idle Mode

*CP: Available in Connected Mode with Pairing Procedure.

*F: Available in Configure Mode

*CM: Available in Physical Link Establish or Connected Mode with Manual Pattern

BLEDK3 Command Set

3.1 Rules of MCU Command Assign

Most of command request sending by MCU will be replied by Command_Complete event. Another new command request is allowed for MCU by receiving Command_Complete event.

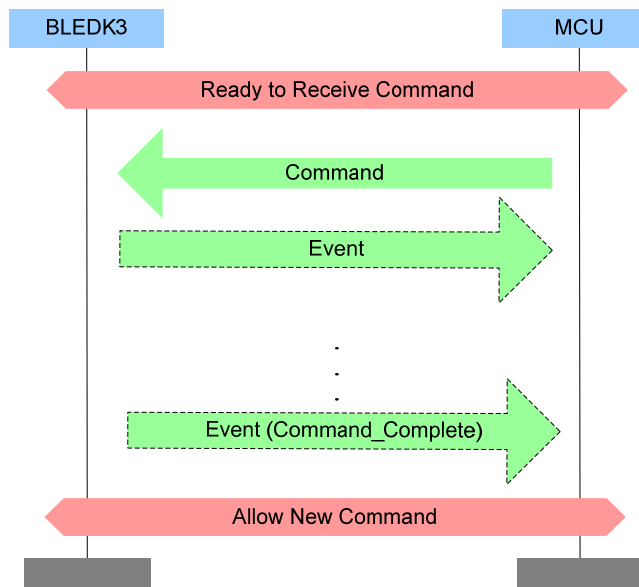

There are some exceptions that no Command_Complete event is sent by the **BLEDK3** to indicate that this command has been completed. Following are the exception commands:

- Read_BLEDK3_Status: The BLEDK3_Status_Report event indicates that this command has been completed.
- LE_Create_Connection: The LE_Connection_Complete event indicates that this connection establishment has been completed. If **BLEDK3** can't achieve the connection establishment, then the LE_Connection_Complete event won't be sent to MCU. MCU can send LE_Create_Connection_Cancel command to stop the action.
- Reset: MCU can know that the command has been completed by getting BLEDK3_Status_Report event.
- Disconnect: The Disconnect_Complete event indicates that this command has been completed.

Besides some command request are allowed for MCU without waiting Command_Complete event after last command request was sending. Those commands are listed as below:

- LE_Create_Connection_Cancel
- Disconnect
- Reset

Command complete guard time. MCU should take care that the sent command is executed or not and do the corresponding action if command is timeout. For most commands, command

BLEDK3 Command Set

complete can be taken to see if command is timeout. For those without command complete, corresponding event received or not can be taken as the response.

But there are also some exceptions. For commands that includes RF communication behaviors, like GAP create connection command, it may depend on the air traffic or parameters to decide the execution time. Another case, GATT Discover All Primary Services command, procedure might include several request/responses. It's not precise for one value to define variables RF behaviors timeout.

By the way, for stack, ATT/SMP protocol timeout value is set to 30 seconds. Which means request/response cannot be taken as timeout within 30 seconds.

Therefore, we have the following suggestions:

- For command without RF communication
 - Suggested command complete/related event timeout: 2 seconds.
- For command with RF communication included
 - Timeout is not suggested. Air traffic might have big influenced on the execution time.

BLEDK3 Command Set

3.2 Common_1 commands

Common group commands are used to configure **BLEDK3** or control of **BLEDK3**. BLEDK3 replies Command_Complete event to notify the command process result after dealing with the commands.

3.2.1 Read_Local_Information (0x01)

Command	Op Code	Command Parameters	Return Parameters
Read_Local_Information	0x01	None	Status, Version, BD_ADDR, HW Version

Description:

This command is used to read local information of **BLEDK3**.

Return Parameters:

Status: *Length: 1 Byte*

Value	Parameter Description
0x00	Command succeeded
0x01 – 0xFF	Command failed. See listing of Error Codes.

Version: *Length: 4 Bytes*

Value	Parameter Description
0xFFFFFFFF	Version information of BLEDK3

BD_ADDR: *Length: 6 Bytes*

Value	Parameter Description
0XXXXXXXXXXXX	Bluetooth address of BLEDK3

HW Version: *Length: 1 Byte*

Value	Parameter Description
0x00	BM70
0x01	BM71
0x02	IS1870
0x03	IS1871

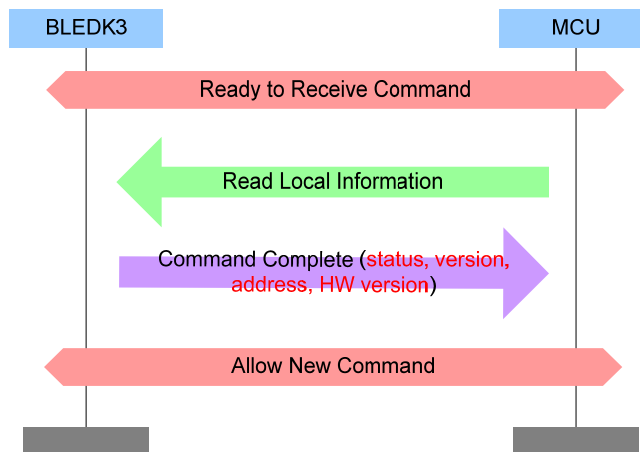

BLEDK3 Command Set

[\[Return to Command Table\]](#)

3.2.2 Reset (0x02)

Command	Op Code	Command Parameters	Return Parameters
Reset	0x02	None	

Description:

This command is used to reset **BLEDK3**.

Command Parameters:

None

Return Parameters:

None

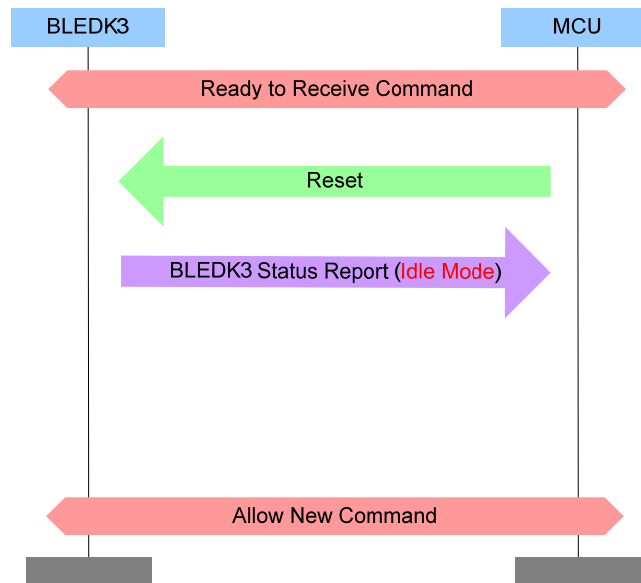

[\[Return to Command Table\]](#)

3.2.3 Read_BLEDK3_Status (0x03)

Command	Op Code	Command Parameters	Return Parameters
Read_BLEDK3_Status	0x03	None	

Description:

This command is used to read status of **BLEDK3**. And the status of **BLEDK3** will be informed by "[BLEDK3 Status Report](#)" event.

Command Parameters:

None

Return Parameters:

BLEDK3 Command Set

None

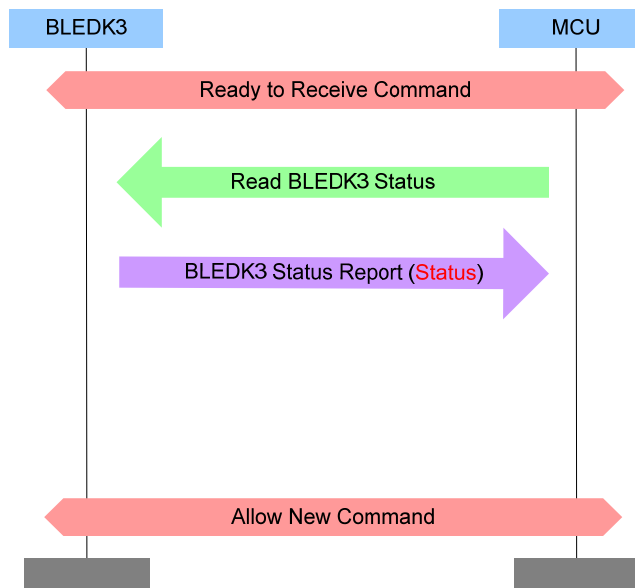

[\[Return to Command Table\]](#)

3.2.4 Read_ADC_Value (0x04)

Command	Op Code	Command Parameters	Return Parameters
Read_ADC_Value	0x04	Channel	Status, Unit, Value

Description:

This command is used to read SAR value from **BLEDK3**.

Command Parameters:

Channel:

Length: 1 Byte

Value	Parameter Description
0x00	Channel 0
0x01	Channel 1
0x02	Channel 2
0x03	Channel 3
0x04	Channel 4
0x05	Channel 5
0x06	Channel 6
0x07	Channel 7
0x08	Channel 8
0x09	Channel 9
0x0a	Channel 10
0x0b	Channel 11
0x0c	Channel 12
0x0d	Channel 13

BLEDK3 Command Set

0x0e	Channel 14
0x0f	Channel 15
0x10	Battery voltage
0x11	Temperature value

Return Parameters:

Status: *Length: 1 Byte*

Value	Parameter Description
0x00	Command succeeded
0x01 – 0xFF	Command failed. See listing of Error Codes.

Unit: *Length: 1 Byte*

Value	Parameter Description
0x00	ADC Value
0x01	0.1V
0x02	0.05V
0x03	0.025V
0x04-0xFF	Reserved

Value: *Length: 2 Byte*

Value	Parameter Description
0xXXXXX	Voltage

[\[Return to Command Table\]](#)

3.2.5 Into_Shutdown_Mode (0x05)

Command	Op Code	Command Parameters	Return Parameters
Into_Shutdown_Mode	0x05	NONE	

Description:

This command is used to drive **BLEDK3** into shutdown mode directly. **BLEDK3** will enter into shutdown mode after Command_Complete is replied.

This command is valid while **BLEDK3** is in Idle Mode only.

Command Parameters:

None

Return Parameters:

Status: *Length: 1 Byte*

Value	Parameter Description
0x00	Command succeeded
0x01 – 0xFF	Command failed. See listing of Error Codes.

BLEDK3 Command Set

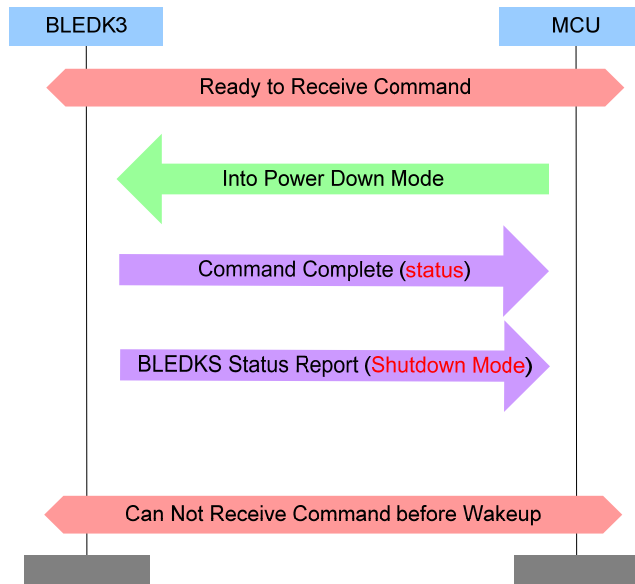

[\[Return to Command Table\]](#)

3.2.6 Debug_Command (0x06)

Command	Op Code	Command Parameters	Return Parameters
Debug_Command	0x06	Debug_Op_Code, Para_1, Para_2,...Para_N	Status, Debug_OP_Code, Data

Description:

This command is used for debugging on read/write memory of **BLEDK3**.

Command Parameters:

Debug_Op_Code: *Length: 1 Byte*

Value	Parameter Description
0xXX	0x01: Read_Memory 0x02: Write_Memory

PARA_1: *Length: 1 Byte*

Value	Parameter Description
0xXX	Read_Memory: Length of memory read. Write_Memory: Length of memory write.

PARA_2: *Length: 1 Byte*

Value	Parameter Description
0xXX	Read_Memory: High byte address of memory read. Write_Memory: High byte address of memory write.

PARA_3: *Length: 1 Byte*

Value	Parameter Description
-------	-----------------------

BLEDK3 Command Set

0xXX	Read_Memory: Low byte address of memory read. Write_Memory: Low byte address of memory write.
------	--

PARA_4: *Length: 1 Byte*

Value	Parameter Description
0xXX	Write_Memory: 1 st data writing to memory.

PARA_N: *Length: 1 Byte*

Value	Parameter Description
0xXX	Write_Memory: rest of Data writing to memory.

Return Parameters:

Status: *Length: 1 Byte*

Value	Parameter Description
0x00	Command succeeded
0x01 – 0xFF	Command failed. See listing of Error Codes.

Debug_OP_Code: *Length: 1 Byte*

Value	Parameter Description
0xXX	0x01: Read_Memory 0x02: Write_Memory

Data: *Length: N Byte*

Value	Parameter Description
0xXX	Returned read memory

[\[Return to Command Table\]](#)

3.2.7 Read_Device_Name (0x07)

Command	Op Code	Command Parameters	Return Parameters
Read_Device_Name	0x07		Status, Device_Name

Description:

This command is used to read device name of **BLEDK3**.

Command Parameters:

None

Return Parameters:

Status: *Length: 1 Byte*

Value	Parameter Description
0x00	Command succeeded
0x01 – 0xFF	Command failed. See listing of Error Codes.

Device_Name: *Length: XX Bytes*

Value	Parameter Description
0xXX	Device name of BLEDK3

BLEDK3 Command Set

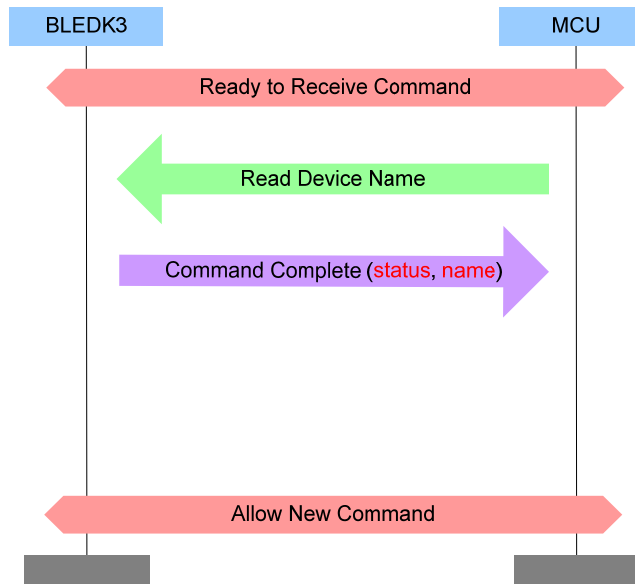

[\[Return to Command Table\]](#)

3.2.8 Write_Device_Name (0x08)

Command	Op Code	Command Parameters	Return Parameters
Write_Device_Name	0x08	Reserved, Device_Name	Status

Description:

This command is used to write device name of **BLEDK3**.

Command Parameters:

RESERVED: *Length: 1 Byte*

Value	Parameter Description
0x00	Reserved for future used

Device_Name: *Length: XX Bytes*

Value	Parameter Description
0xXX	Device name of BLEDK3

Return Parameters:

Status: *Length: 1 Byte*

Value	Parameter Description
0x00	Command succeeded
0x01 – 0xFF	Command failed. See listing of Error Codes.

BLEDK3 Command Set

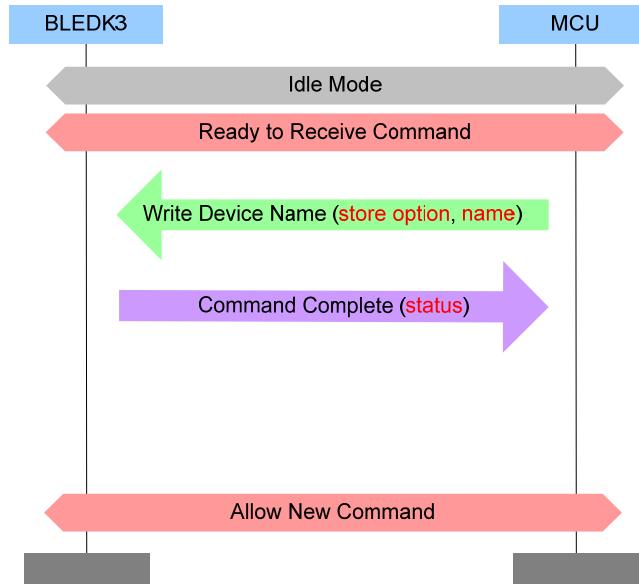

[\[Return to Command Table\]](#)

3.2.9 Erase_All_Paired_Device_Information (0x09)

Command	Op Code	Command Parameters	Return Parameters
Erase_All_Paired_Device_Information	0x09		Status

Description:

This command is used to erase all of the paired device information saved in **BLEDK3** and it is valid while **BLEDK3** is in Idle Mode or Configure Mode

Command Parameters:

None

Return Parameters:

Status:

Length: 1 Byte

Value	Parameter Description
0x00	Command succeeded
0x01 – 0xFF	Command failed. See listing of Error Codes.

BLEDK3 Command Set

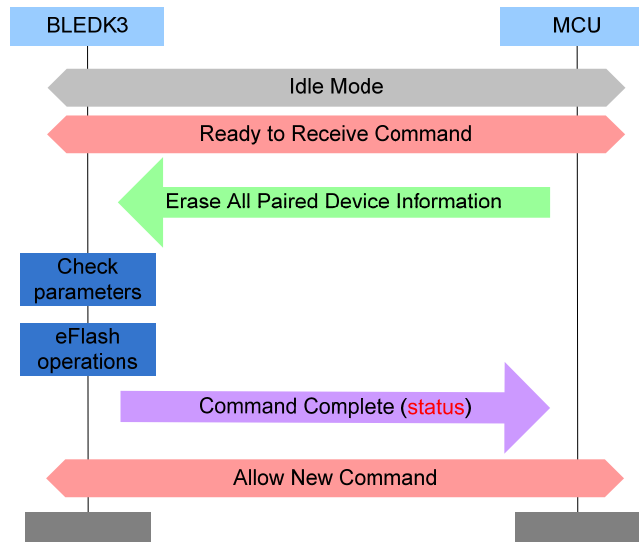

[\[Return to Command Table\]](#)

3.2.10 Read_Pairing_Mode_Setting (0x0A)

Command	Op Code	Command Parameters	Return Parameters
Read_Pairing_Mode_Setting	0x0A		Status, IO_Capability

Description:

This command is used to read pairing mode setting of **BLEDK3**.

Command Parameters:

None

Return Parameters:

Status: *Length: 1 Byte*

Value	Parameter Description
0x00	Command succeeded
0x01 – 0xFF	Command failed. See listing of Error Codes.

IO_Capability: *Length: 1 Byte*

Value	Parameter Description
0x00	DisplayOnly
0x01	DisplayYesNo
0x02	KeyboardOnly
0x03	NoInputNoOutput
0x04	KeyboardDisplay

BLEDK3 Command Set

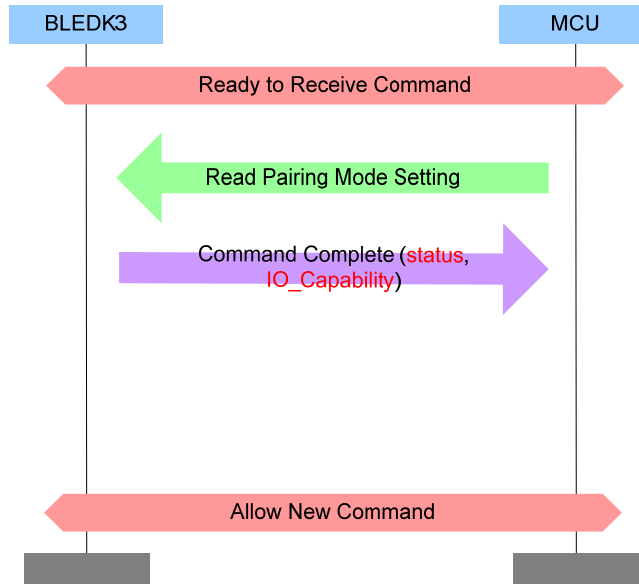

[\[Return to Command Table\]](#)

3.2.11 Write_Pairing_Mode_Setting (0x0B)

Command	Op Code	Command Parameters	Return Parameters
Write_Pairing_Mode_Setting	0x0B	Reserved, IO_Capability	Status

Description:

This command is used to write pairing mode setting of **BLEDK3** and it is valid while **BLEDK3** is in Idle Mode or Configure Mode.

Command Parameters:

Reserved:

Length: 1 Byte

Value	Parameter Description
0x00	Reserved for future used

IO_Capability:

Length: 1 Byte

Value	Parameter Description
0x00	DisplayOnly
0x01	DisplayYesNo
0x02	KeyboardOnly
0x03	NoInputNoOutput
0x04	KeyboardDisplay

Return Parameters:

Status:

Length: 1 Byte

Value	Parameter Description
0x00	Command succeeded

BLEDK3 Command Set

0x01 – 0xFF

Command failed. See listing of Error Codes.

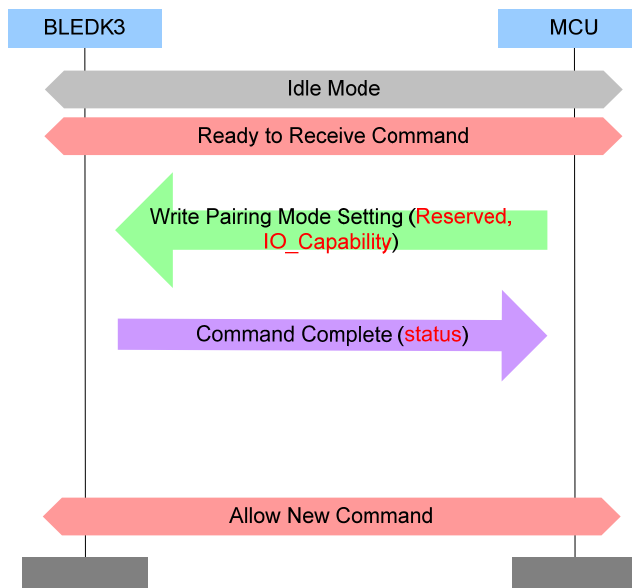

[\[Return to Command Table\]](#)

3.2.12 Read_All_Paired_Device_Information (0x0C)

Command	Op Code	Command Parameters	Return Parameters
Read_All_Paired_Device_Information	0x0C		Status, Num_Of_Paired_Device, Device_List

Description:

This command is used to read all paired devices information of **BLEDK3** and it is valid while **BLEDK3** is in Idle Mode or Configure Mode.

Command Parameters:

None

Return Parameters:

Status:

Length: 1 Byte

Value	Parameter Description
0x00	Command succeeded
0x01 – 0xFF	Command failed. See listing of Error Codes.

Num_Of_Paired_Device:

Length: 1 Byte

Value	Parameter Description
0xFF	Number of paired devices

Device_List: Max to 8 sets

Device_Index:

Length: 1 Byte

Value	Parameter Description
-------	-----------------------

BLEDK3 Command Set

0xXX	Paired device index
<i>Priority:</i> <i>Length: 1 Byte</i>	
Value	Parameter Description
0xXX	Link priority(0x01: Latest linked device)
<i>Device_Address:</i> <i>Length: 6 Bytes</i>	
Value	Parameter Description
0XXXXXXXXXXXXX	Paired device Bluetooth address

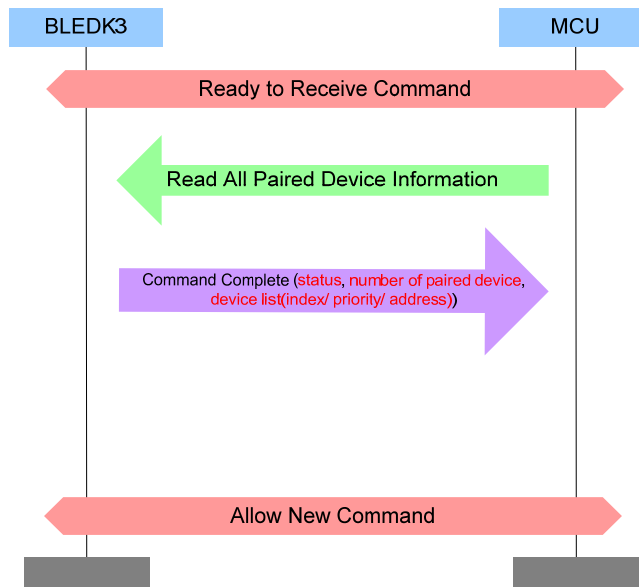

[\[Return to Command Table\]](#)

3.2.13 Delete_Paired_Device (0x0D)

Command	Op Code	Command Parameters	Return Parameters
Delete_Paired_Device	0x0D	Device_Index	Status

Description:

This command is used to delete paired device from **BLEDK3** and it is valid while **BLEDK3** is in Idle Mode or Configure Mode.

Command Parameters:

Device_Index: *Length: 1 Byte*

Value	Parameter Description
0xXX	The range of device index is from 0 to 7.

Return Parameters:

Status: *Length: 1 Byte*

Value	Parameter Description
0x00	Command succeeded

BLEDK3 Command Set

0x01 – 0xFF

Command failed. See listing of Error Codes.

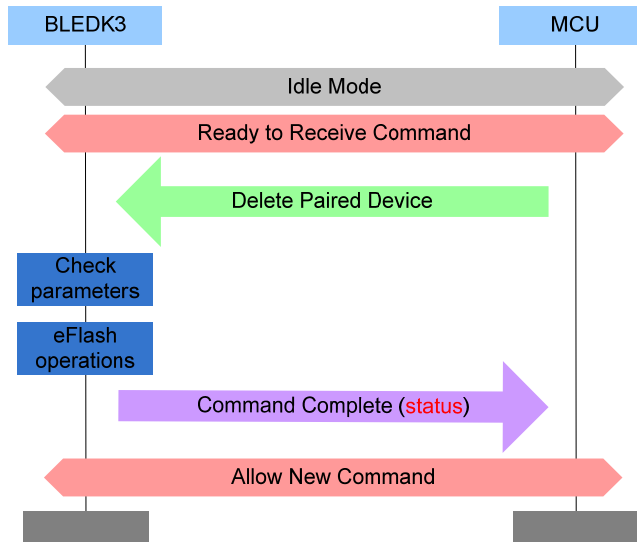

[\[Return to Command Table\]](#)

3.2.14 DIO_Control (0x0E)

Command	Op Code	Command Parameters	Return Parameters
DIO_Control	0x0E	P0OE_Value, P1OE_Value, P2OE_Value, P3OE_Value, P0_Output_Value, P1_Output_Value, P2_Output_Value, P3_Output_Value P0_Ctrl_Enable, P1_Ctrl_Enable, P2_Ctrl_Enable, P3_Ctrl_Enable	Status, P0_Valid_Ctrl_DIO, P1_Valid_Ctrl_DIO, P2_Valid_Ctrl_DIO, P3_Valid_Ctrl_DIO, P0_Read_Value, P1_Read_Value, P2_Read_Value, P3_Read_Value,

Description:

This command is used to control digital IOs of **BLEDK3**. The controlled DIOs should not be configured as other function used. BLEDK3 would ignore the invalid control on functional DIOs. For example, P2_0 used for system configuration and it cannot be controlled by this command. Or P0_2 is configured as LED display and it also cannot be controlled by this command.

Parameter Px_Ctrl_Enable means pins that MCU wants to control. EX:
P3_Control_Enable = 0x01 means that MCU want to control P3_0 only.

Command Parameters:

BLEDK3 Command Set

P0OE_VALUE: *Length: 1 Byte*

Value	Parameter Description
0bXXXXXXXX	0: Set DIO to be input
	1: Set DIO to be output

P1OE_VALUE: *Length: 1 Byte*

Value	Parameter Description
0bXXXXXXXX	0: Set DIO to be input
	1: Set DIO to be output

P2OE_VALUE: *Length: 1 Byte*

Value	Parameter Description
0bXXXXXXXX	0: Set DIO to be input
	1: Set DIO to be output

P3OE_VALUE: *Length: 1 Byte*

Value	Parameter Description
0bXXXXXXXX	0: Set DIO to be input
	1: Set DIO to be output

P0_OUTPUT_VALUE: *Length: 1 Byte*

Value	Parameter Description
0xXX	Port 0 output value. This parameter is available when P0OE set to output enable

P1_OUTPUT_VALUE: *Length: 1 Byte*

Value	Parameter Description
0xXX	Port 1 output value. This parameter is available when P1OE set to output enable

P2_OUTPUT_VALUE: *Length: 1 Byte*

Value	Parameter Description
0xXX	Port 2 output value. This parameter is available when P2OE set to output enable

P3_OUTPUT_VALUE: *Length: 1 Byte*

Value	Parameter Description
0xXX	Port 3 output value. This parameter is available when P3OE set to output enable

P0_CTRL_ENABLE: *Length: 1 Byte*

Value	Parameter Description
0bXXXXXXXX	0: Disable DIO pin control
	1: Enable DIO pin control

P1_CTRL_ENABLE: *Length: 1 Byte*

Value	Parameter Description
0bXXXXXXXX	0: Disable DIO pin control
	1: Enable DIO pin control

P2_CTRL_ENABLE: *Length: 1 Byte*

Value	Parameter Description
0bXXXXXXXX	0: Disable DIO pin control
	1: Enable DIO pin control

BLEDK3 Command Set

P3_CTRL_ENABLE:

Length: 1 Byte

Value	Parameter Description
0bXXXXXXXX	0: Disable DIO pin control 1: Enable DIO pin control

Return Parameters:

Status:

Length: 1 Byte

Value	Parameter Description
0x00	Command succeeded
0x01 – 0xFF	Command failed. See listing of Error Codes.

P0_VALID_CTRL_DIO:

Length: 1 Byte

Value	Parameter Description
0xXX	Port 0 valid control pins value

P1_VALID_CTRL_DIO:

Length: 1 Byte

Value	Parameter Description
0xXX	Port 1 valid control pins value

P2_VALID_CTRL_DIO:

Length: 1 Byte

Value	Parameter Description
0xXX	Port 2 valid control pins value

P3_VALID_CTRL_DIO:

Length: 1 Byte

Value	Parameter Description
0xXX	Port 3 valid control pins value

P0_READ_VALUE:

Length: 1 Byte

Value	Parameter Description
0xXX	Port 0 value

P1_READ_VALUE:

Length: 1 Byte

Value	Parameter Description
0xXX	Port 1 value

P2_READ_VALUE:

Length: 1 Byte

Value	Parameter Description
0xXX	Port 2 value

P3_READ_VALUE:

Length: 1 Byte

Value	Parameter Description
0xXX	Port 3 value

[\[Return to Command Table\]](#)

3.2.15 PWM_Control (0x0F)

Command	Op Code	Command Parameters	Return Parameters
PWM_Control	0x0F	Channel, PWM_Enable, Clock_Source, Top_Value,	Status

BLEDK3 Command Set

Compare_Value, Output_Inverse

Description:

This command is used to control PWM of **BLEDK3**.

The minimum Top_value is 0x0001 and the maximum Top_value is 0xFFFF. The Compare_value range is 0x0000 to 0xFFFF and Compare_value must smaller than Top_value. Also, for PWM0, channel 1, there are two output GPIOs. Depending on preferred output GPIO or HW limitation, select either P21 or P36 as PWM0 output.

Command Parameters:

Channel: *Length: 1 Byte*

Value	Parameter Description
0x00	Channel 1 with output to P21
0x01	Channel 2
0x02	Channel 3
0x03	Channel 4
0x04	Channel 1 with output to P36

PWM_Enable: *Length: 1 Byte*

Value	Parameter Description
0x00	PWM disable
0x01	PWM enable

Clock_Source: *Length: 1 Byte*

Value	Parameter Description
0x00	32 KHz
0x01	1024 KHz
0x02	16 MHz

Top_Value: *Length: 2 Byte*

Value	Parameter Description
0xXXXX	Top value

Compare_Value: *Length: 2 Byte*

Value	Parameter Description
0xXXXX	Compare value

Output_Inverse: *Length: 1 Byte*

Value	Parameter Description
0x00	Normal output
0x01	Inverse output

Return Parameters:

Status: *Length: 1 Byte*

Value	Parameter Description
0x00	Command succeeded

BLEDK3 Command Set

0x01 – 0xFF Command failed. See listing of Error Codes.

[\[Return to Command Table\]](#)

3.3 GAP Commands

The GAP group commands are used to manage **BLEDK3** Bluetooth connection related capability. For most commands, **BLEDK3** replies the Command_Complete event to notify the result of command process.

3.3.1 Read_RSSI_Value (0x10)

Command	Op Code	Command Parameters	Return Parameters
Read_RSSI_Value	0x10	Connection_Handle	Status, RSSI_Value

Description:

This command is used to read RSSI value for peer connection.

This command is valid while Bluetooth link is successfully established between **BLEDK3** and remote host.

Command Parameters:

Connection_Handle:

Length: 1 Bytes

Value	Parameter Description
0xXX	Connection Handle

Return Parameters:

Status:

Length: 1 Byte

Value	Parameter Description
0x00	Command succeeded
0x01 – 0xFF	Command failed. See listing of Error Codes.

RSSI_Value:

Length: 1 Byte

Value	Parameter Description
0xXX	RSSI Value

BLEDK3 Command Set

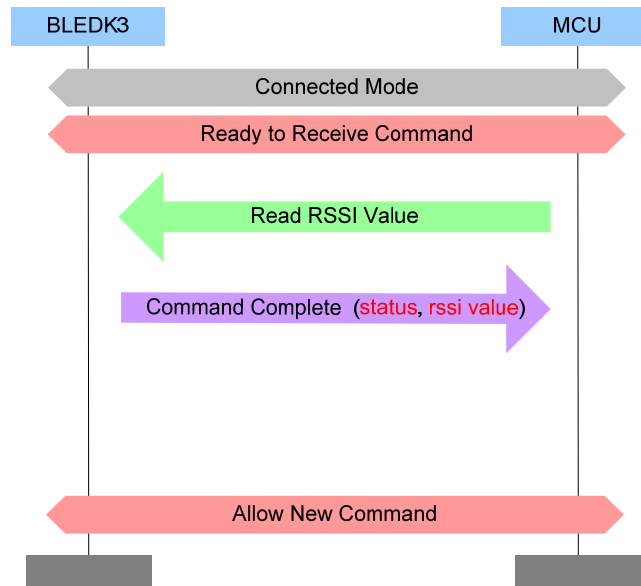

[\[Return to Command Table\]](#)

3.3.2 Write_Adv_Data (0x11)

Command	Op Code	Command Parameters	Return Parameters
Write_Adv_Data	0x11	Store_Option, Advertising_Data	Status

Description:

This command is used to update the advertise data.

This command is valid while **BLEDK3** is in Idle Mode or Configure Mode.

Command Parameters:

Store_Option: *Length: 1 Byte*

Value	Parameter Description
0x00	Advertising Data won't be stored
0x80	Beacon Data won't be stored

Advertising_Data *Length: 1 to 31 Bytes*

Value	Parameter Description
0xXX	Advertising Data/Beacon Data

Return Parameters:

Status: *Length: 1 Byte*

Value	Parameter Description
0x00	Command succeeded
0x01 – 0xFF	Command failed. See listing of Error Codes.

BLEDK3 Command Set

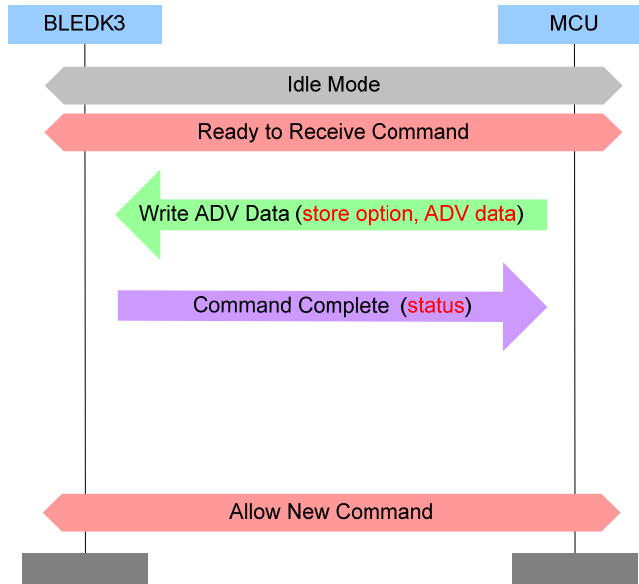

[\[Return to Command Table\]](#)

3.3.3 Write_Scan_Res_Data (0x12)

Command	Op Code	Command Parameters	Return Parameters
Write_Scan_Res_Data	0x12	Reserved, Scan_Res_Data	Status

Description:

This command is used to update the Scan_Res data.

This command is valid while **BLEDK3** is in Idle Mode or Configure Mode.

Command Parameters:

Reserved:

Length: 1 Byte

Value	Parameter Description
0x00	Reserved for future used

Scan_Res_Data

Length: 1 to 31 Bytes

Value	Parameter Description
0xXX	Scan Response Data

Return Parameters:

Status:

Length: 1 Byte

Value	Parameter Description
0x00	Command succeeded
0x01 – 0xFF	Command failed. See listing of Error Codes.

BLEDK3 Command Set

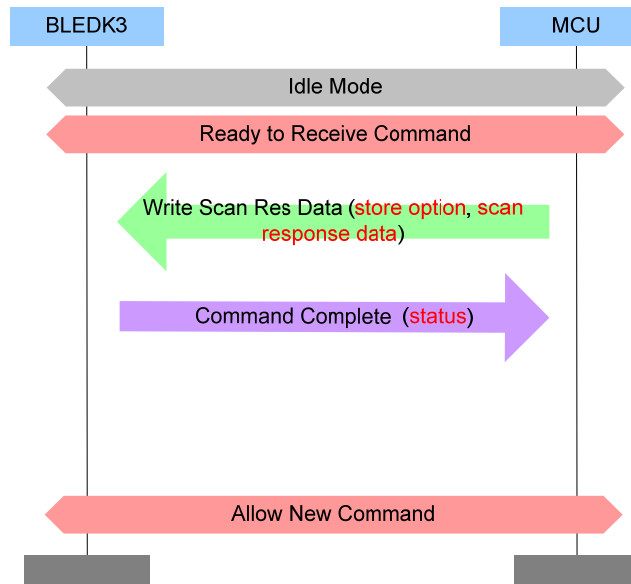

[\[Return to Command Table\]](#)

3.3.4 Set_Advertising_Parameter (0x13)

Command	Op Code	Command Parameters	Return Parameters
Advertising_Mode_Setting	0x13	Advertising_Interval Advertising_Type, Direct_Address_Type, Direct_Address,	Status

Description:

This command is used to set advertising parameters and it is valid while **BLEDK3** is in Idle Mode or Configure Mode.

Command Parameters:

Advertising_Interval:

Length: 2 Bytes

Value	Parameter Description
0xXXXX	Advertising interval for non-directed advertising. Range: 0x0020 to 0x4000 Default: N = 0x0800 (1.28 second) Time = N * 0.625 msec Time Range: 20 ms to 10.24 sec

Advertising_Type:

Length: 1 Byte

Value	Parameter Description
0x00	Connectable undirected advertising. It is used to make BLEDK3 into standby mode.
0x01	Connectable directed advertising. It is used to make BLEDK3 into link back mode.
0x02	Scannable undirected advertising. It is used to make BLEDK3 into broadcast mode. And it will reply advertising packet only for the observer passive scanning or active

BLEDK3 Command Set

	scanning to receive advertising events.
0x03	Non connectable undirected advertising. It is used to make BLEDK3 into broadcast mode.

0x04	Proprietary Beacon Setting
------	----------------------------

Direct_Address_Type: *Length: 1 Byte*

Value	Parameter Description
0x00	Public Device Address
0x01	Random Device Address

Direct_Address: *Length: 6 Bytes*

Value	Parameter Description
0XXXXXXXXXXXXX	Public Device Address or Random Device Address of the device to be connected

Return Parameters:

Status: *Length: 1 Byte*

Value	Parameter Description
0x00	Command succeeded
0x01 – 0xFF	Command failed. See listing of Error Codes.

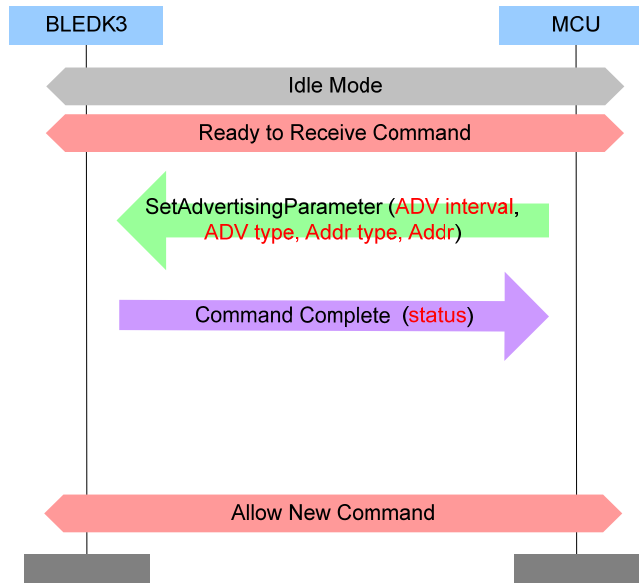

[\[Return to Command Table\]](#)

3.3.5 Set_Scan_Parameter (0x15)

Command	Op Code	Command Parameters	Return Parameters
Set_Scan_Parameters	0x15	Scan_Interval, Scan_Window Scan_Type	Status

Description:

BLEDK3 Command Set

This command is used to set scan parameters, start scanning and whether **BLEDK3** shall filter duplicate advertising reports to MCU. It is valid while **BLEDK3** is in Idle Mode only.

Command Parameters:

Scan_Interval

Length: 2 Byte

Value	Parameter Description
0xXXXX	This is defined as the time interval from when the Controller started its last BLEDK3 scan until it begins the subsequent BLEDK3 scan. Range: 0x0004 to 0x4000 Default: 0x0010 (10 ms) Time = N * 0.625 msec Time Range: 2.5 msec to 10.24 seconds

Scan_Window

Length: 2 Byte

Value	Parameter Description
0xXXXX	The duration of the LE scan. Scan_Window shall be less than or equal to Scan_Interval. Range: 0x0004 to 0x4000 Default: 0x0010 (10 ms) Time = N * 0.625 msec Time Range: 2.5 msec to 10240 msec

Scan_Type

Length: 1 Byte

Value	Parameter Description
0x00	Passive Scanning. No SCAN_REQ packets shall be sent. (default)
0x01	Active scanning. SCAN_REQ packets may be sent.

Return Parameters:

Status:

Length: 1 Byte

Value	Parameter Description
0x00	Command succeeded
0x01 – 0xFF	Command failed. See listing of Error Codes.

[\[Return to Command Table\]](#)

3.3.6 Set_Scan_Enable (0x16)

Command	Op Code	Command Parameters	Return Parameters
Discover_Peripheral	0x16	Scan_Enable, Filter_Duplicates	Status

Description:

This command is used to cancel discover peripheral and it is valid while **BLEDK3** is in Idle Mode only.

Command Parameters:

BLEDK3 Command Set

Scan_Enable: *Length: 1 Byte*

Value	Parameter Description
0x00	Scanning disabled
0x01	Scanning enabled

Filter_Duplicate: *Length: 1 Byte*

Value	Parameter Description
0x00	Duplicate filtering disabled.
0x01	Duplicate filtering enabled.

Return Parameters:

Status: *Length: 1 Byte*

Value	Parameter Description
0x00	Command succeeded
0x01 – 0xFF	Command failed. See listing of Error Codes.

[\[Return to Command Table\]](#)

3.3.7 LE_Create_Connection (0x17)

Command	Op Code	Command Parameters	Return Parameters
Create_Connection	0x17	Filter_Policy, Peer_Address_Type, Peer_Address,	

Description:

This command is used to create a connection to a connectable advertiser and it is valid while **BLEDK3** is in Idle Mode only.

Command Parameters:

Filter_Policy: *Length: 1 Byte*

Value	Parameter Description
0x00	White list is not used to determine which advertiser to connect to. Peer_Address_Type and Peer_Address shall be used.
0x01	White list is used to determine which advertiser to connect to. Peer_Address_Type and Peer_Address shall be ignored.

Peer_Address_Type: *Length: 1 Byte*

Value	Parameter Description
0x00	Public Device Address
0x01	Random Device Address

Peer_Address: *Length: 6 Bytes*

Value	Parameter Description
0XXXXXXXXXXXXX	Public Device Address or Random Device Address of the device to be connected

Return Parameters:

None

BLEDK3 Command Set

Note: No Command_Complete event is sent by the **BLEDK3** to indicate that this command has been completed. Instead, the LE_Connection_Complete event indicates that this command has been completed.

[\[Return to Command Table\]](#)

3.3.8 LE_Create_Connection_Cancel (0x18)

Command	Op Code	Command Parameters	Return Parameters
LE_Create_Connection_Cancel	0x18	NONE	Status

Description:

This command is used to cancel the LE_Create_Connection command. This command shall only be issued after the LE_Create_Connection command has been issued (Under Connecting Mode).

Command Parameters:

None

Status:

Length: 1 Byte

Value	Parameter Description
0x00	Command succeeded
0x01 – 0xFF	Command failed. See listing of Error Codes.

[\[Return to Command Table\]](#)

3.3.9 Connection_Parameter_Update_Req (0x19)

Command	Op Code	Command Parameters	Return Parameters
Connection_Parameter_Update_Req	0x19	Connection_Handle Conn_Interval, Conn_Latency, Supervision_Timeout	Status

Description:

This command is used to change connection parameters of a connection. This command is valid while Bluetooth link is successfully established between **BLEDK3** and remote host.

Command Parameters:

Connection_Handle:

Length: 1 Byte

Value	Parameter Description
0xXX	Connection Handle

Conn_Interval:

Length: 2 Bytes

Value	Parameter Description
0xXXXXX	Minimum value for the connection event interval. This shall be less than or equal to Conn_Interval_Max. Range: 0x0006 to 0x0C80 Time = N * 1.25 msec

BLEDK3 Command Set

Time Range: 7.5 msec to 4 seconds.

Conn_Latency:

Length: 2 Bytes

Value	Parameter Description
0xXXXX	Slave latency for the connection in number of connection events. Range: 0x0000 to 0x01F4

Supervision_Timeout:

Length: 2 Bytes

Value	Parameter Description
0xXXXX	Supervision timeout for the LE Link Range: 0x000A to 0x0C80 Time = N * 10 msec Time Range: 100 msec to 32 seconds

Return Parameters:

Status:

Length: 1 Byte

Value	Parameter Description
0x00	Command succeeded
0x01 – 0xFF	Command failed. See listing of Error Codes.

[\[Return to Command Table\]](#)

3.3.10 Disconnect (0x1B)

Command	Op Code	Command Parameters	Return Parameters
Disconnect	0x1B	Reserved	

Description:

This command is used to terminate a connection. This command is valid while Bluetooth link is successfully established between **BLEDK3** and remote host.

Command Parameters:

Reserved:

Length: 1 Byte

Value	Parameter Description
0x00	Always set this byte to 0

Return Parameters:

None

Note: No Command_Complete event is sent by the **BLEDK3** to indicate that this command has been completed. Instead, the Disconnection_Complete event indicates that this command has been completed.

BLEDK3 Command Set

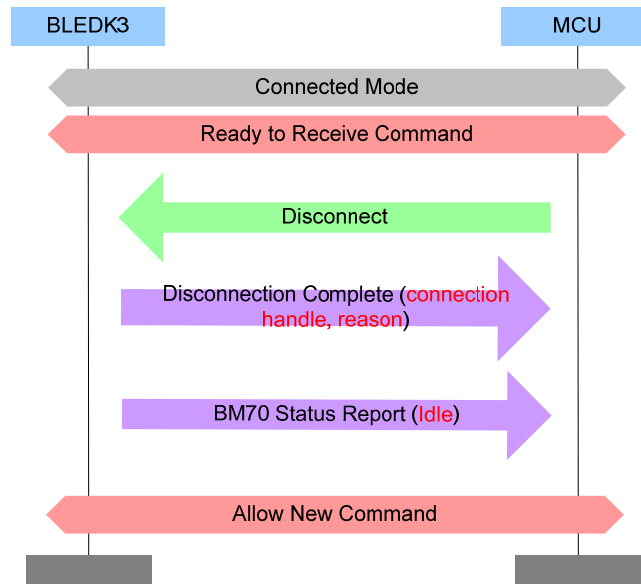

[\[Return to Command Table\]](#)

3.3.11 Set_Adv_Enable (0x1C)

Command	Op Code	Command Parameters	Return Parameters
Set_Adv_Enable	0x1C	Mode	Status

Description:

This command is used to configure invisible setting of **BLEDK3** and it is valid while **BLEDK3** is in Idle Mode only.

Command Parameters:

Mode: *Length: 1 Byte*

Value	Parameter Description
0x00	Leave Standby Mode
0x01	Enter Standby Mode
0x02	Enter Standby Mode and only connectable for trust device
0x81	Enter Standby Mode with Beacon Enabled
0x82	Enter Standby Mode with Beacon Enabled and only connectable for trust device

Return Parameters:

Status: *Length: 1 Byte*

Value	Parameter Description
0x00	Command succeeded
0x01 – 0xFF	Command failed. See listing of Error Codes.

BLEDK3 Command Set

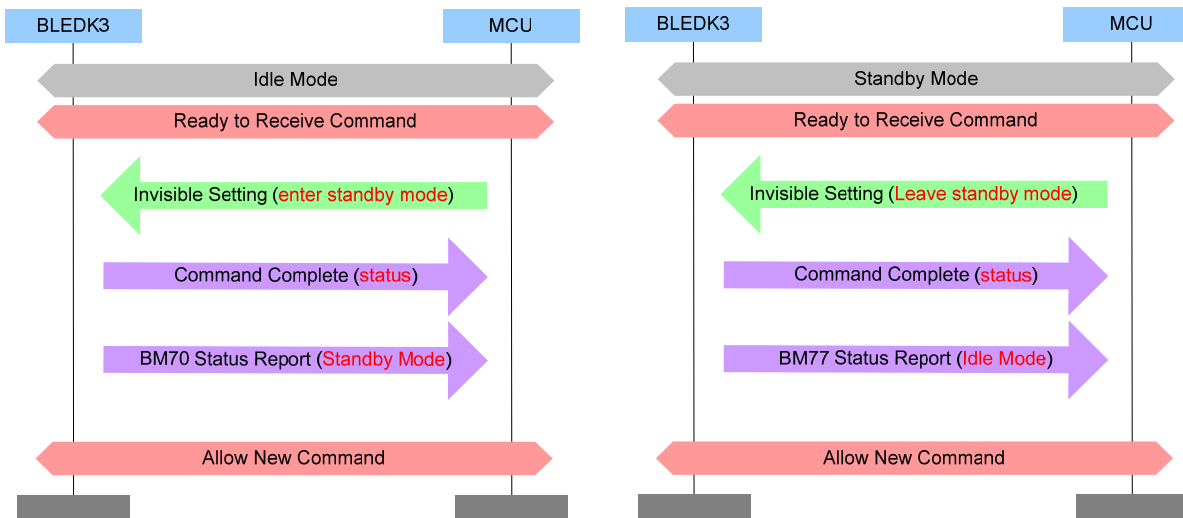

[\[Return to Command Table\]](#)

3.3.12 Read_Remote_Device_Name (0x1F)

Command	Op Code	Command Parameters	Return Parameters
Read_Remote_Device_Name	0x1F	Connection_Handle	Status, Device_Name

Description:

This command is used to read remote device name. This command is valid while Bluetooth link is successfully established between **BLEDK3** and remote host.

Command Parameters:

Connection_Handle:

Length: 1 Byte

Value	Parameter Description
0xXX	Connection Handle

Return Parameters:

Status:

Length: 1 Byte

Value	Parameter Description
0x00	Command succeeded
0x01 – 0xFF	Command failed. See listing of Error Codes.

Device_Name:

Length: XX Bytes

Value	Parameter Description
0xXX	Remote Device Name

[\[Return to Command Table\]](#)

3.4 GATT Client Commands

GATT client group commands are used for GATT client procedure

BLEDK3 Command Set

3.4.1 Discover_All_Primary_Services (0x30)

Command	Op Code	Command Parameters	Return Parameters
Discover_All_Primary_Services	0x30	Connection_Handle	Status

Description:

This command is used to discovery all primary services on a server.

Command Parameters:

Connection_Handle: *Length: 1 Byte*

Value	Parameter Description
0xXX	Connection Handle

Return Parameters:

Status: *Length: 1 Byte*

Value	Parameter Description
0x00	Command succeeded
0x01 – 0xFF	Command failed. See listing of Error Codes.

[\[Return to Command Table\]](#)

3.4.2 Discover_Specific_Primary_Service_Characteristics (0x31)

Command	Op Code	Command Parameters	Return Parameters
Discover_Specific_Primary_Service_Characteristics	0x31	Connection_Handle, Service_UUID	Status

Description:

This command is used to find all the characteristic declarations and characteristic descriptor's Attribute handles and Attribute Types within a service definition on a server when only the service handle range is known.

Command Parameters:

Connection_Handle: *Length: 1 Byte*

Value	Parameter Description
0xXX	Connection Handle

Service_UUID: *Length: 2 or 16 Bytes*

Value	Parameter Description
0xXX	16-bit Bluetooth UUID or 128-bit UUID

Return Parameters:

Status: *Length: 1 Byte*

Value	Parameter Description
0x00	Command succeeded
0x01 – 0xFF	Command failed. See listing of Error Codes.

BLEDK3 Command Set

[\[Return to Command Table\]](#)

3.4.3 Read_Characteristic_Value (0x32)

Command	Op Code	Command Parameters	Return Parameters
Read_Characteristic_Value	0x32	Connection_Handle, Characteristic_Value_Handle	Status, Characteristic_Value

Description:

This command is used to read a Characteristic Value from a server.

Command Parameters:

Connection_Handle: *Length: 1 Byte*

Value	Parameter Description
0xXX	Connection Handle

Characteristic_Value_Handle: *Length: 2 Bytes*

Value	Parameter Description
0xXXXX	Characteristic Value Handle

Return Parameters:

Status: *Length: 1 Byte*

Value	Parameter Description
0x00	Command succeeded
0x01 – 0xFF	Command failed. See listing of Error Codes.

Characteristic_Value: *Length: 1 to 20 Bytes*

Value	Parameter Description
0xXX	Characteristic Value

[\[Return to Command Table\]](#)

3.4.4 Read_Using_Characteristic_UUID (0x33)

Command	Op Code	Command Parameters	Return Parameters
Read_Using_Characteristic_UUID	0x33	Connection_Handle, Characteristic_UUID	Status, Characteristic_Value_Handle, Characteristic_Value

Description:

This command is used to read a Characteristic Value from a server when the client only knows the characteristic UUID and does not know the handle of the characteristic.

Command Parameters:

Connection_Handle: *Length: 1 Byte*

Value	Parameter Description
-------	-----------------------

BLEDK3 Command Set

0xXX	Connection Handle
<i>Characteristic_UUID:</i> <i>Length: 2 or 16 Bytes</i>	
Value	Parameter Description
0XXXXX..	Characteristic UUID

Return Parameters:

<i>Status:</i> <i>Length: 1 Byte</i>	
Value	Parameter Description
0x00	Command succeeded
0x01 – 0xFF	Command failed. See listing of Error Codes.
<i>Characteristic_Value_Handle:</i> <i>Length: 2 Bytes</i>	
Value	Parameter Description
0XXXXX	Characteristic Value Handle
<i>Characteristic_Value:</i> <i>Length: 1 to 20 Bytes</i>	
Value	Parameter Description
0xXX	Characteristic Value

[\[Return to Command Table\]](#)

3.4.5 Write_Characteristic_Value (0x34)

Command	Op Code	Command Parameters	Return Parameters
Write_Characteristic_Value	0x34	Connection_Handle, Write_Type, Characteristic_Value_Handle, Characteristic_Value	Status

Description:

This command is used to write a Characteristic Value to a server.

Command Parameters:

<i>Connection_Handle:</i> <i>Length: 1 Byte</i>	
Value	Parameter Description
0xXX	Connection Handle
<i>Write_Type:</i> <i>Length: 1 Byte</i>	
Value	Parameter Description
0x00	With Response
0x01	Without Response
<i>Characteristic_Value_Handle:</i> <i>Length: 2 Bytes</i>	
Value	Parameter Description
0XXXXX	Characteristic Value Handle
<i>Characteristic_Value:</i> <i>Length: 1 to 20 Bytes</i>	
Value	Parameter Description

BLEDK3 Command Set

0xXX	Characteristic Value
------	----------------------

Return Parameters:

Status: *Length: 1 Byte*

Value	Parameter Description
-------	-----------------------

0x00	Command succeeded
------	-------------------

0x01 – 0xFF	Command failed. See listing of Error Codes.
-------------	---

[\[Return to Command Table\]](#)

3.4.6 Enable_Transparent (0x35)

Command	Op Code	Command Parameters	Return Parameters
Enable_Transparent	0x35	Connection_Handle, Server_Transparent_Ctrl, Client_Transparent_Mode	Status

Description:

This command is used to enable ISSC_TRANS_TX service of **BLEDK3**.

Command Parameters:

Connection_Handle: *Length: 1 Byte*

Value	Parameter Description
-------	-----------------------

0xXX	Connection Handle
------	-------------------

Server_Transparent_Ctrl: *Length: 1 Byte*

Value	Parameter Description
-------	-----------------------

0x00	Disable transparent data transmit of server. (Default)
------	--

0x01	Enable transparent data transmit of server.
------	---

Client_Transparent_Mode: *Length: 1 Byte*

Value	Parameter Description
-------	-----------------------

0x00	Client send transparent data by Write_Req. (Default)
------	--

0x01	Client send transparent data by Write_Cmd.
------	--

Return Parameters:

Status: *Length: 1 Byte*

Value	Parameter Description
-------	-----------------------

0x00	Command succeeded
------	-------------------

0x01 – 0xFF	Command failed. See listing of Error Codes.
-------------	---

[\[Return to Command Table\]](#)

3.5 GATT Server Commands

3.5.1 Send_Characteristic_Value (0x38)

Command	Op Code	Command Parameters	Return Parameters
Send_Characteristic_Value	0x38	Conn_Handle,	Status

BLEDK3 Command Set

Characteristic_Value_Handle,
Characteristic_Value

Description:

This command is used to send characteristic value to GATT client.

Command Parameters:

Conn_Handle: *Length: 1 Bytes*

Value	Parameter Description
0xXX	Connection Handle

Characteristic_Value_Handle: *Length: 2 Bytes*

Value	Parameter Description
0xXXXX	Characteristic Value Handle

Characteristic_Value: *Length: 1 to 20 Bytes*

Value	Parameter Description
0xXX	Characteristic Value

Return Parameters:

Status: *Length: 1 Byte*

Value	Parameter Description
0x00	Command succeeded
0x01 – 0xFF	Command failed. See listing of Error Codes.

[\[Return to Command Table\]](#)

3.5.2 Update_Characteristic_Value (0x39)

Command	Op Code	Command Parameters	Return Parameters
Update_Characteristic_Value	0x39	Characteristic_Value_Handle, Characteristic_Value	Status

Description:

This command is used to update existing characteristic value of **BLEDK3**.

Command Parameters:

Characteristic_Value_Handle: *Length: 2 Bytes*

Value	Parameter Description
0xXXXX	characteristic value handle

Characteristic_Value: *Length: 1 to 20 Bytes*

Value	Parameter Description
0xXX	characteristic value

Return Parameters:

Status: *Length: 1 Byte*

BLEDK3 Command Set

Value	Parameter Description
0x00	Command succeeded
0x01 – 0xFF	Command failed. See listing of Error Codes.

[\[Return to Command Table\]](#)

3.5.3 Read_Local_Characteristic_Value (0x3A)

Command	Op Code	Command Parameters	Return Parameters
Read_Local_Characteristic_Value	0x3A	Characteristic_Value_Handle	Status, Characteristic_Value

Description:

This command is used to read existing characteristic value of **BLEDK3**.

Command Parameters:

Characteristic_Value_Handle: *Length: 2 Bytes*

Value	Parameter Description
0xFFFF	characteristic value handle

Return Parameters:

Status: *Length: 1 Byte*

Value	Parameter Description
0x00	Command succeeded
0x01 – 0xFF	Command failed. See listing of Error Codes.

Characteristic_Value: *Length: XX Bytes*

Value	Parameter Description
0xFF	characteristic value

[\[Return to Command Table\]](#)

3.5.4 Read_Local_All_Primary_Service (0x3B)

Command	Op Code	Command Parameters	Return Parameters
Read_Local_All_Primary_Service	0x3B		Status

Description:

This command is used to read all primary service of **BLEDK3**.

Command Parameters:

None

Return Parameters:

Status: *Length: 1 Byte*

Value	Parameter Description
-------	-----------------------

BLEDK3 Command Set

0x00	Command succeeded
0x01 – 0xFF	Command failed. See listing of Error Codes.

[\[Return to Command Table\]](#)

3.5.5 Read_Local_Specific_Primary_Service (0x3C)

Command	Op Code	Command Parameters	Return Parameters
Read_Local_Specific_Primary_Service	0x3C	Service_UUID	Status

Description:

This command is used to read specific primary service of **BLEDK3**.

Command Parameters:

Service_UUID: *Length: 2 or 16 Bytes*

Value	Parameter Description
0xXX	16-bit Bluetooth UUID or 128-bit UUID

Return Parameters:

Status: *Length: 1 Byte*

Value	Parameter Description
0x00	Command succeeded
0x01 – 0xFF	Command failed. See listing of Error Codes.

[\[Return to Command Table\]](#)

3.5.6 Send_Write_Response (0x3D)

Command	Op Code	Command Parameters	Return Parameters
Send_Write_Response	0x3D	Connection_Handle, Request_Opcode, Attribute_Handle, Error_Code	Status

Description:

This command is used to manually respond write request to the GATT client. BLEDK3 will send “Write Response” with error code 0x00. Otherwise, “Error Response” with corresponding error code is sent. This command should only be sent after receiving write request and the manually sending “Write Response” option is on.

Command Parameters:

Connection_Handle: *Length: 1 Byte*

Value	Parameter Description
0xXX	Connection Handle

Request_Opcode: *Length: 1 Byte*

Value	Parameter Description
-------	-----------------------

BLEDK3 Command Set

0x12 Write Request. The opcode of the request to respond.
Attribute_Handle: *Length: 2 Bytes*

Value	Parameter Description
0xXXXX	The handle of the attribute which the request perform

Error_Code: *Length: 1 Byte*

Value	Parameter Description
0x00	No error. Send Write Response
0x01	Invalid Handle
0x02	Read Not Permitted
0x03	Write Not Permitted
0x04	Invalid PDU
0x05	Insufficient Authentication
0x06	Request Not Supported
0x07	Invalid Offset
0x08	Insufficient Authorization
0x09	Prepare Queue Full
0x0A	Attribute Not Found
0x0B	Attribute Not Long
0x0C	Insufficient Encryption Key Size
0x0D	Invalid Attribute Value Length
0x0E	Unlikely Error
0x0F	Insufficient Encryption
0x10	Unsupported Group Type
0x11	Insufficient Resources
0x12 – 0x7F	Reserved
0x80 – 0x9F	Application defined errors
0xA0 – 0xDF	Reserved
0xE0 – 0xFF	Common Profile and Service Error Codes

Return Parameters:

Status: *Length: 1 Byte*

Value	Parameter Description
0x00	Command succeeded
0x01 – 0xFF	Command failed. See listing of Error Codes.

[\[Return to Command Table\]](#)

3.6 GATT Transparent Command

3.6.1 Send_Transparent_Data (0x3F)

Command	Op Code	Command Parameters	Return Parameters
Send_Transparent_Data	0x3F	Connection_Handle, Transparent_Data	Status

Description:

BLEDK3 Command Set

This command is used to send transparent data by ISSC_TRANS_TX service.

Command Parameters:

Connection_Handle: *Length: 1 Byte*

Value	Parameter Description
0x00	Connection Handle

Transparent_Data: *Length: N Bytes*

Value	Parameter Description
0xXX	Transparent_Data. Maximum length of transparent data is 640 bytes

Return Parameters:

Status: *Length: 1 Byte*

Value	Parameter Description
0x00	Command succeeded
0x01 – 0xFF	Command failed. See listing of Error Codes.

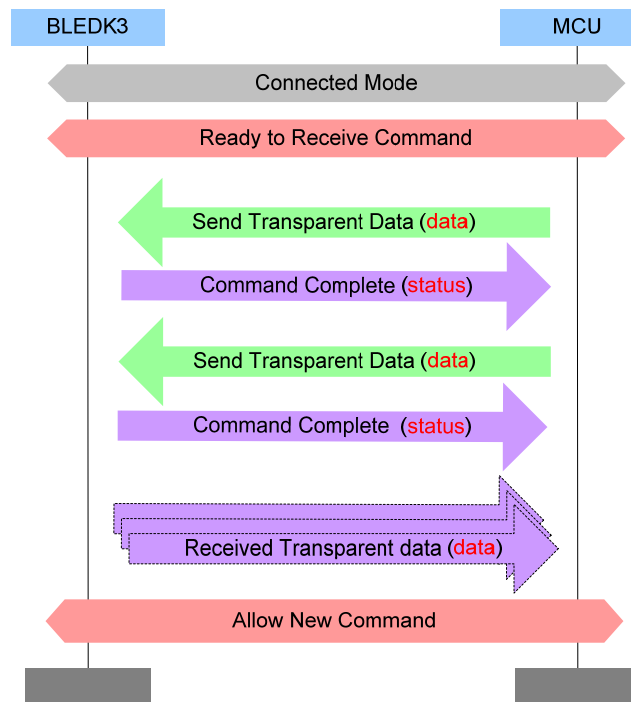

[\[Return to Command Table\]](#)

3.7 Pairing Commands

3.7.1 Passkey_Entry_Res (0x40)

Command	Op Code	Command Parameters	Return Parameters
Passkey_Entry_Res	0x40	Connection_Handle Notification_Type, Entered_Passkey	Status

Description:

BLEDK3 Command Set

This command is used to response passkey entry request from **BLEDK3**.

Command Parameters:

Connection_Handle: *Length: 1 Byte*

Value	Parameter Description
0xXX	Connection Handle

Notification_Type: *Length: 1 Byte*

Value	Parameter Description
0x01	Passkey digit entered
0x02	Passkey digit erased
0x03	Passkey cleared
0x04	Passkey entry completed

Entered_Passkey: *Length: 1 Byte*

Value	Parameter Description
0xXX	Entered Digital Passkey character. It is valid only while the Notification_type is 0x01. 0x30~0x39: "0" ~"9"

Return Parameters:

Status: *Length: 1 Byte*

Value	Parameter Description
0x00	Command succeeded
0x01 – 0xFF	Command failed. See listing of Error Codes.

BLEDK3 Command Set

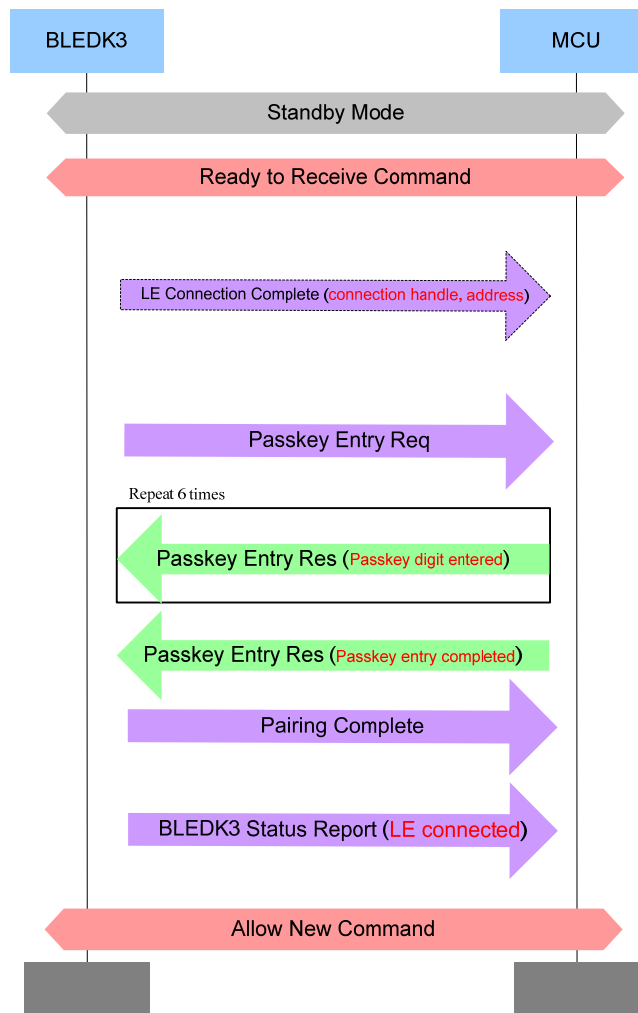

[\[Return to Command Table\]](#)

3.7.2 User_Confirm_Res (0x41)

Command	Op Code	Command Parameters	Return Parameters
User_Confirm_Res	0x41	Connection_Handle option	Status

Description:

This command is used to response passkey entry request from **BLEDK3**.

Command Parameters:

Connection_Handle: *Length: 1 Byte*

Value	Parameter Description
0xXX	Connection Handle

Notification_Type: *Length: 1 Byte*

Value	Parameter Description
0x00	Entered information is Yes

BLEDK3 Command Set

0x01 Entered information is No

Return Parameters:

Status:

Length: 1 Byte

Value	Parameter Description
0x00	Command succeeded
0x01 – 0xFF	Command failed. See listing of Error Codes.

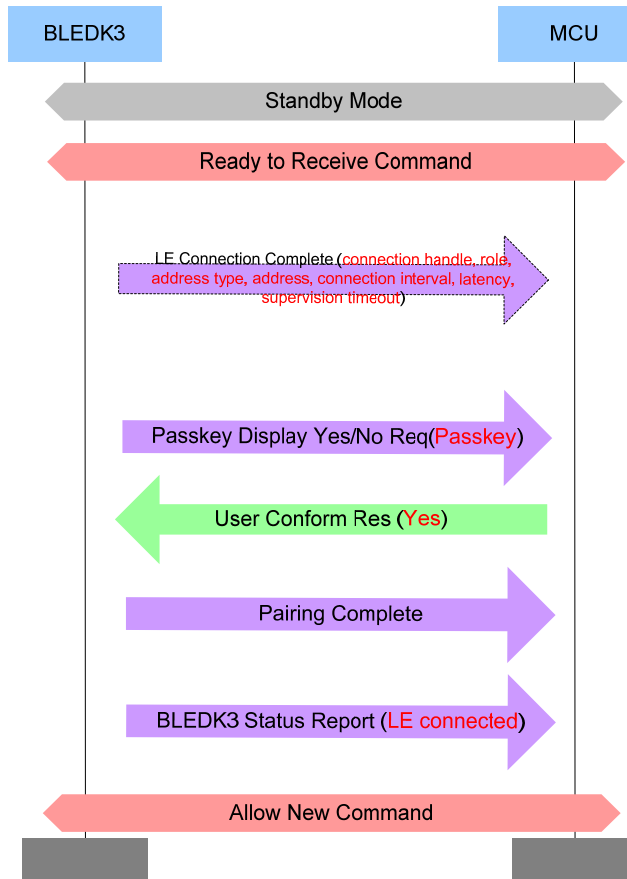

[\[Return to Command Table\]](#)

3.7.3 Pairing_Request (0x42)

Command	Op Code	Command Parameters	Return Parameters
Pairing_Request	0x42	Connection_Handle	Status

Description:

This command is used to initiate pairing procedure.

Command Parameters:

Connection_Handle:

Length: 1 Byte

Value	Parameter Description
0xXX	Connection Handle

Return Parameters:

BLEDK3 Command Set

Status: *Length: 1 Byte*

Value	Parameter Description
0x00	Command succeeded
0x01 – 0xFF	Command failed. See listing of Error Codes.

[\[Return to Command Table\]](#)

3.8 Common_2_Command

MCU sends the Common Command to **BLEDK3** for specific purpose. **BLEDK3** will reply the Command Complete event to notify the command process result.

3.8.1 Leave_Configure_Mode (0x52)

Command	Op Code	Command Parameters	Return Parameters
Leave_Configure_Mode	0x52	Option	Status

Description:

BLEDK3 will leave configure mode if “Leave_Configure_Mode” command is received.

Command Parameters:

Option: *Length: 1 Byte*

Value	Parameter Description
0x00	None
0x01	Disable configure mode forever

Return Parameters:

Status: *Length: 1 Byte*

Value	Parameter Description
0x00	Command succeeded
0x01 – 0xFF	Command failed. See listing of Error Codes.

BLEDK3 Command Set

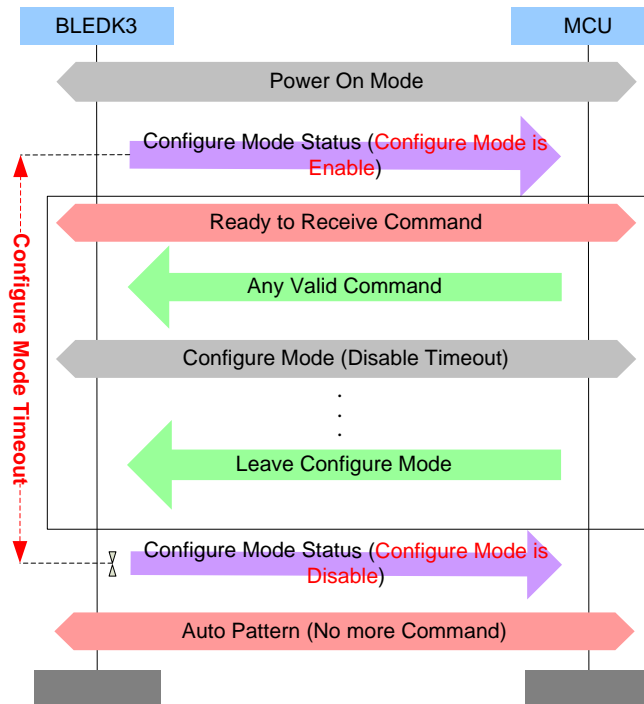

[\[Return to Command Table\]](#)

BLEDK3 Command Set

4 EVENT OP CODE DEFINITION

Event Type	OP code	Event
Pairing	0x60	Passkey_Entry_Req
	0x61	Pairing_Complete
	0x62	Passkey_Confirm_Req
GAP	0x70	Advertising_Report
	0x71	LE_Connection_Complete
	0x72	Disconnection_Complete
	0x73	Connection_Parameter_Update_Notify
Common	0x80	Command_Complete
	0x81	BLEDK3_Status_Report
	0x8F	Configure_Mode_Status
GATT Client	0x90	Discover_All_Primary_Services_Res
	0x91	Discover_Specific_Primary_Service_Characteristic_Res
	0x92	Discover_All_Characteristic_Descriptors_Res
	0x93	Characteristic_Value_Received
GATT Server	0x98	Client_Write_Characteristic_Value
GATT Transparent	0x9A	Received_Transparent_Data

4.1 Pairing Event

4.1.1 Passkey_Entry_Req (0x60)

Event	OpCode	Event Parameters
Passkey_Entry_Req	0x60	Connection_Handle

Description:

This event is used to inform MCU that **BLEDK3** has received Passkey Request.

Event Parameters:

Connection_Handle:

Length: 1 Byte

Value	Parameter Description
0xXX	Connection_Handle to be used to identify a connection between two Bluetooth devices

[\[Return to Event Table\]](#)

4.1.2 Pairing_Complete (0x61)

Event	OpCode	Event Parameters
Pairing_Complete	0x61	Connection_Handle Result

Description:

This event is used to inform MCU that **BLEDK3** pairing process has been finished.

BLEDK3 Command Set

Event Parameters:

Connection_Handle: *Length: 1 Byte*

Value	Parameter Description
0xXX	Connection_Handle to be used to identify a connection between two Bluetooth devices

Result: *Length: 1 Byte*

Value	Parameter Description
0x00	Pairing Complete
0x01	Pairing Fail
0x02	Pairing Timeout

[\[Return to Event Table\]](#)

4.1.3 Passkey_Confirm_Req (0x62)

Event	OpCode	Event Parameters
Passkey_Confirm_Req	0x62	Connection_Handle Displayed_Passkey

Description:

This event is used to inform MCU that **BLEDK3** has received user confirm request.

Event Parameters:

Connection_Handle: *Length: 1 Byte*

Value	Parameter Description
0xXX	Connection_Handle to be used to identify a connection between two Bluetooth devices

Displayed_Passkey: *Length: 1 Byte*

Value	Parameter Description
0xXX	Numeric for MCU to display

[\[Return to Event Table\]](#)

4.2 GAP Event

4.2.1 Advertising_Report (0x70)

Event	OpCode	Event Parameters
Advertising_Report	0x70	Event_Type, Address_Type, Address, Length, Data, RSSI

Description:

This event indicates that a Bluetooth device or multiple Bluetooth devices have responded to

BLEDK3 Command Set

an active Scan or received some information during a passive scan.

Event Parameters:

Event_Type: *Length: 1 Byte*

Value	Parameter Description
0x00	Connectable undirected advertising (ADV_IND).
0x01	Connectable directed advertising (ADV_DIRECT_IND)
0x02	Scannable undirected advertising (ADV_SCAN_IND)
0x03	Non connectable undirected advertising (ADV_NONCONN_IND)
0x04	Scan Response (SCAN_RSP)

Address_Type: *Length: 1 Byte*

Value	Parameter Description
0x00	Public Device Address
0x01	Random Device Address

Address: *Length: 6 Bytes*

Value	Parameter Description
0XXXXXXXXXXXXX	Public Device Address or Random Device Address for each device which responded.

Length_Data: *Length: 1 Byte*

Value	Parameter Description
0x00~0x1F	Length of the Data[i] field for each device which responded

Data: *Length: Length_Data[i] Bytes*

Value	Parameter Description
0x00~0x1F	Length_Data[i] octets of advertising or scan response data

RSSI: *Length: 1 Byte*

Value	Parameter Description
N	Size: 1 Octet (signed integer) Range: $-127 \leq N \leq +20$ Units: dBm
127	RSSI is not available

[\[Return to Event Table\]](#)

4.2.2 LE_Connection_Complete (0x71)

Event	OpCode	Event Parameters
LE_Connection_Complete	0x71	Status, Connection_Handle, Role, Peer_Address_Type, Peer_Address, Conn_Interval, Conn_Latency, Supervision_Timeout,

Description:

This event is used to inform MCU that a LE connection has been created.

Event Parameters:

BLEDK3 Command Set

Status: *Length: 1 Byte*

Value	Parameter Description
0x00	Connection successfully completed.
0x01~0xff	Connection failed to complete.

Connection_Handle: *Length: 1 Byte*

Value	Parameter Description
0xXX	Connection_Handle to be used to identify a connection between two Bluetooth devices

Role: *Length: 1 Byte*

Value	Parameter Description
0x00	Connection is master
0x01	Connection is slave

Peer_Address_Type: *Length: 1 Byte*

Value	Parameter Description
0x00	Peer is using a Public Device Address
0x01	Peer is using a Random Device Address
0x02	Peer is paired device

Peer_Address: *Length: 6 Bytes*

Value	Parameter Description
0XXXXXXXXXXXX	Public Device Address or Random Device Address of the peer device

Conn_Interval: *Length: 2 Bytes*

Value	Parameter Description
0XXXXX	Connection interval used on this connection. Range: 0x0006 to 0x0C80 Time = N * 1.25 msec Time Range: 7.5 msec to 4000 msec.

Conn_Latency: *Length: 2 Bytes*

Value	Parameter Description
0XXXXX	Connection latency for this connection. Range: 0x0006 to 0x0C80 Time = N * 1.25 msec Time Range: 7.5 msec to 4000 msec.

SuperVision_Timeout: *Length: 2 Bytes*

Value	Parameter Description
0XXXXX	Connection supervision timeout. Range: 0x000A to 0x0C80 Time = N * 10 msec Time Range: 100 msec to 32 seconds

[\[Return to Event Table\]](#)

BLEDK3 Command Set

4.2.3 Disconnection_Complete (0x72)

Event	OpCode	Event Parameters
Disconnection_Complete	0x72	Connection_Handle, Reason

Description:

This event is used to inform that the connection has been terminated.

Event Parameters:

Connection_Handle: *Length: 1 Byte*

Value	Parameter Description
0xXX	Connection_Handle to be used to identify a connection between two Bluetooth devices

Reason: *Length: 1 Byte*

Value	Parameter Description
0xXX	Disconnection reason. See listing of Error Codes.

[\[Return to Event Table\]](#)

4.2.4 Connection_Parameter_Update_Notify (0x73)

Event	OpCode	Event Parameters
Connection_Parameter_Update_Notify	0x73	Connection_Handle, Conn_Interval, Conn_Latency, Supervision_Timeout

Description:

This event is used to inform that the connection parameter has been updated.

Event Parameters:

Connection_Handle: *Length: 1 Byte*

Value	Parameter Description
0xXX	Connection Handle

Conn_Interval: *Length: 2 Byte*

Value	Parameter Description
0xXXXXX	Minimum value for the connection event interval. This shall be less than or equal to Conn_Interval_Max. Range: 0x0006 to 0x0C80 Time = N * 1.25 msec Time Range: 7.5 msec to 4 seconds.

Conn_Latency: *Length: 2 Bytes*

Value	Parameter Description
0xXXXXX	Slave latency for the connection in number of connection events. Range: 0x0000 to 0x01F4

Supervision_Timeout: *Length: 2 Bytes*

BLEDK3 Command Set

Value	Parameter Description
0xXXXX	Supervision timeout for the LE Link Range: 0x000A to 0x0C80 Time = N * 10 msec Time Range: 100 msec to 32 seconds

[\[Return to Event Table\]](#)

4.3 Common Event

4.3.1 Command_Complete (0x80)

Event	OpCode	Event Parameters
Command_Complete	0x80	Command_OpCode, Return_Parameters

Description:

This event is used to response of commands.

Event Parameters:

Command_OpCode:

Length: 1 Byte

Value	Parameter Description
0xXX	Opcode of the command which caused this event.

Return_Parameters

Length: Depends on Command

Value	Parameter Description
0xXX	Opcode of the command which caused this event.

[\[Return to Event Table\]](#)

4.3.2 BLEDK3_Status_Report (0x81)

Event	OpCode	Event Parameters
BLEDK3_Status_Report	0x81	Status

Description:

This event is used to inform MCU status of **BLEDK3** while status is changed and response of "[Read BLEDK3 Status](#)" command.

Event Parameters:

Status:

Length: 1 Byte

Value	Parameter Description
0xXX	See listing of BLEDK3 Status.

[\[Return to Event Table\]](#)

4.3.3 Configure_Mode_Status (0x8F)

Event	OpCode	Event Parameters
Configure_Mode_Status	0x8f	Status

Description:

BLEDK3 Command Set

This event is used to inform MCU Configure Mode status of **BLEDK3**.

Event Parameters:

Status: *Length: 1 Byte*

Value	Parameter Description
0x00	Configure Mode is Disabled.
0x01	Configure Mode is Enabled

[\[Return to Event Table\]](#)

4.4 GATT Client Event

4.4.1 Discover_All_Primary_Services_Res (0x90)

Event	OpCode	Event Parameters
Discover_All_Primary_Service s_Res	0x90	Connection_Handle, Length, Attribute_Data

Description:

This event is used to response of “Discover_All_Primary_Services” command.

Event Parameters:

Connection_Handle: *Length: 1 Byte*

Value	Parameter Description
0xXX	Connection Handle

Length: *Length: 1 Byte*

Value	Parameter Description
0xXX	The size of each attribute data

Attribute_Data: *Length: 6 to 20 Bytes*

The Attribute Data field is comprised of a list of attribute data.

Start Group Handle	End Group Handle	Service UUID
2 Bytes	2 Bytes	(Length -4) Bytes

[\[Return to Event Table\]](#)

4.4.2 Discover_Specific_Primary_Service_Characteristic_Res (0x91)

Event	OpCode	Event Parameters
Discover_Specific_Primary_S ervice_Characteristics_Res	0x91	Connection_Handle, Length, Attribute_Data

Description:

This event is used to response of “Discover_Specific_Primary_Service_Characteristics” command.

Event Parameters:

BLEDK3 Command Set

Connection_Handle:

Length: 1 Byte

Value	Parameter Description
0xXX	Connection Handle

Length:

Length: 1 Byte

Value	Parameter Description
0xXX	The size of each attribute handle-value pair

Attribute_Data:

Length: 2 to 18 Bytes

The Attribute Data field is comprised of a list of attribute handle and value pairs for characteristic declaration.

Attribute Handle	Attribute Value
2 Bytes	(Length -2) Bytes

Attribute Value of Characteristic Declaration:

Attribute Value		
Characteristic Properties (1 Byte)	Characteristic Value Attribute Handle (2 Bytes)	Characteristic UUID (2 or 16 Bytes)

Properties	Value
Broadcast	0x01
Read	0x02
Write Without Response	0x04
Write	0x08
Notify	0x10
Indicate	0x20
Authenticated Signed Writes	0x40
Extended Properties	0x80

[\[Return to Event Table\]](#)

4.4.3 Discover_All_Characteristic_Descriptors_Res (0x92)

Event	OpCode	Event Parameters
Discover_All_Characteristic_Descriptors_Res	0x92	Connection_Handle, Format, Information_Data

Description:

This event is used to response of “Discover_All_Characteristic_Descriptors” command.

Event Parameters:

BLEDK3 Command Set

Connection_Handle: *Length: 1 Byte*

Value	Parameter Description
0xXX	Connection Handle

Format: *Length: 1 Byte*

Value	Parameter Description
0x01	A list of 1 or more handles with their 16-bit Bluetooth UUIDs
0x02	A list of 1 or more handles with their 128-bit UUIDs

Information_Data: *Length: 4 to 20 Bytes*

The information data is comprised of a list of data defined in the tables below depending on the value chosen for the format.

Handle	16-bit Bluetooth UUID
2 Bytes	2 Bytes

Format 0x01-handle and 16-bit Bluetooth UUIDs

Handle	128-bit Bluetooth UUID
2 Octets	16 Octets

Format 0x02-handle and 128-bit UUIDs

[\[Return to Event Table\]](#)

4.4.4 Characteristic_Value_Received (0x93)

Event	OpCode	Event Parameters
Characteristic_Value_Receive d	0x93	Connection_Handle, Characteristic_Value_Handle, Characteristic_Value

Description:

This event is used to inform MCU that **BLEDK3** has received a characteristic value Notification or indication from GATT Server.

Event Parameters:

Connection_Handle: *Length: 1 Byte*

Value	Parameter Description
0xXX	Connection Handle

Characteristic_Value_Handle: *Length: 2 Byte*

Value	Parameter Description
0xXXXX	Characteristic Value Handle

Characteristic_Value: *Length: 1 to 20 Bytes*

Value	Parameter Description
0xXX	Characteristic Value

[\[Return to Event Table\]](#)

BLEDK3 Command Set

4.5 GATT Server Event

4.5.1 Client_Write_Characteristic_Value (0x98)

Event	OpCode	Event Parameters
Client_Write_Characteristic_Value	0x98	Connection_Handle, Characteristic_Value_Handle, Characteristic_Value

Description:

This event is used to inform MCU that GATT Client has written a Characteristic Value to **BLEDK3**

Event Parameters:

Connection_Handle: *Length: 1 Byte*

Value	Parameter Description
0xXX	Connection Handle

Characteristic_Value_Handle: *Length: 2 Bytes*

Value	Parameter Description
0xFFFF	Characteristic Value Handle

Characteristic_Value: *Length: 1 to 20 Bytes*

Value	Parameter Description
0xXX	Characteristic Value

[\[Return to Event Table\]](#)

4.6 GATT Transparent Event

4.6.1 Received_Transparent_Data (0x9a)

Event	OpCode	Event Parameters
Received_Transparent_Data	0x9a	Connection_Handle, Transparent_Data

Description:

This event is used to inform MCU that **BLEDK3** has received transparent data by ISSC_TRANS_RX service.

Event Parameters:

Connection_Handle: *Length: 1 Byte*

Value	Parameter Description
0xXX	Connection Handle

Transparent_Data: *Length: n Bytes*

Value	Parameter Description
0xXX	Transparent data

[\[Return to Event Table\]](#)

BLEDK3 Command Set

5 OPERATION DEFINITION

5.1 Application Pattern Configuration

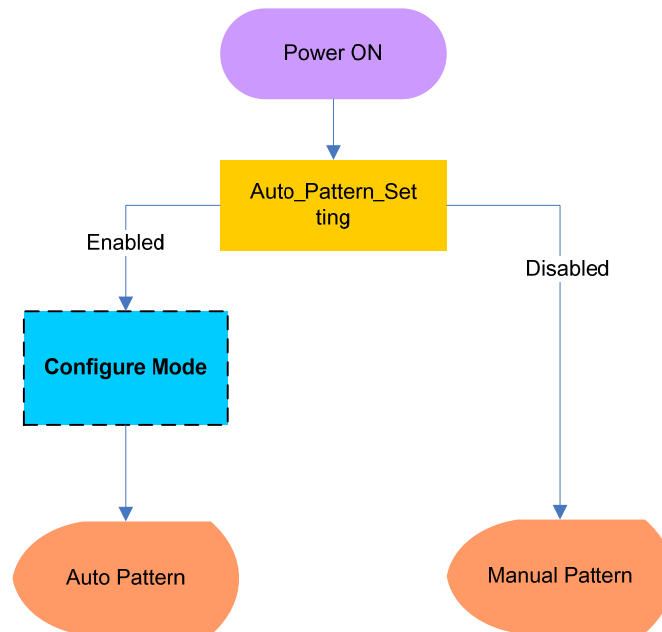

5.1.1 Auto Pattern

BLEDK3 will be executed base on internal state machine that can be configured by UI tool.

- BLEDK3 may into “Configure Mode” by UI tool setting and MCU command assigned.
- Some commands are available at “Configure Mode” and “Connected Mode with pairing procedure” only.
- The data pipe is “Transparent Pipe”.

5.1.2 Manual Pattern

BLEDK3 will be executed base on MCU command totally.

- MCU must handle BLEDK3 state by correct commands.
- The data pipe is “Protocol Pipe”.

5.2 Mode

5.2.1 Scanning Mode

BLEDK3 tries to find advertising devices in the area. BLEDK3 would receive advertising packets from peer device and report these to MCU.

5.2.2 Connecting Mode

BLEDK3 tries to initiate a connection to an advertiser

BLEDK3 Command Set

5.2.3 Standby Mode

BLEDK3 is under Bluetooth discoverable and connectable mode. **BLEDK3** enables the Undirected Advertising. It can also be paired by another device in this mode.

5.2.4 Broadcast Mode

BLEDK3 is under Bluetooth discoverable mode. And **BLEDK3** has no connection capacity in this mode.

5.2.5 Transparent Service Enabled Mode

Bluetooth connection is established successfully, and GATT data session is opened.

5.2.6 Idle Mode

There's no any activity of **BLEDK3** until MCU assign the new command. And Idle mode is only available in Manual Pattern.

5.2.7 Shutdown Mode

BLEDK3 enters into shutdown mode situation.

- **Auto Pattern:**
 - **BLEDK3** Enter into shutdown mode automatically
 - Wakeup Trigger: Wakeup pin or UART_RX_IND pin
- **Manual Pattern:**
 - **BLEDK3** Enter into shutdown mode by MCU command assign
 - Wakeup Trigger: Wakeup pin or UART_RX_IND pin

5.2.8 Configure Mode

It is used to configure relative setting before **BLEDK3** enter into **Auto Pattern**

BLEDK3 Command Set

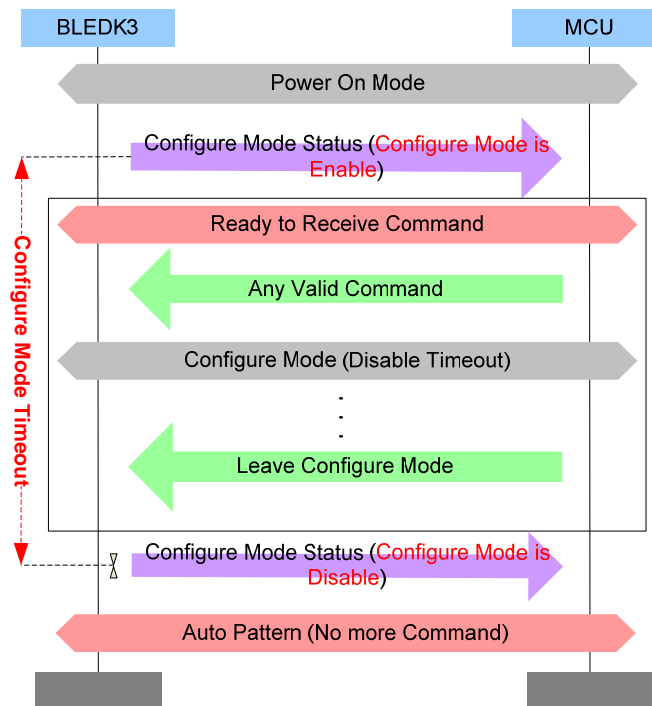

5.2.9 BLE Connected Mode

Bluetooth connection is established successfully and GATT data session is not been enabled.

5.3 Data Pipe

- **Transparent Pipe:** The exchange data between MCU and APP will be transferred directly.
- **Protocol Pipe:**
 - MCU to APP: MCU use "Send_Transparent_Data" command to send data.
 - APP to MCU: BLEDK3 use "Recieved_Transparent_Data" event to inform MCU.

BLEDK3 Command Set

5.4 BLEDK3 State Indication in Auto Pattern

BLEDK3 status in Auto Pattern is composed of STATUS1_IND and STATUS2_IND. To get whole status information, both STATUS1_IND and STATUS2_IND should be assigned in configurable GPIOs by UI tool. Below table shows the definition of BLEDK3 status.

STATUS1_IND / STATUS2_IND	Status	Description
H/H	Shutdown Mode	BLEDK3 is shutdown
H/L	Standby Mode	BLEDK3 sends advertising packets and wait for connection. BLEDK3 is under discoverable and connectable.
L/L	BLE Connected Mode	BLE link is established and CCCD of ISSC_Transparent_TX characteristic is disabled
L/H	Transparent Service Enabled Mode	BLE link is established and CCCD of ISSC_Transparent_TX characteristic is enabled

BLEDK3 Command Set

6 STATE MACHINE CHARTS

6.1 Power on Flow

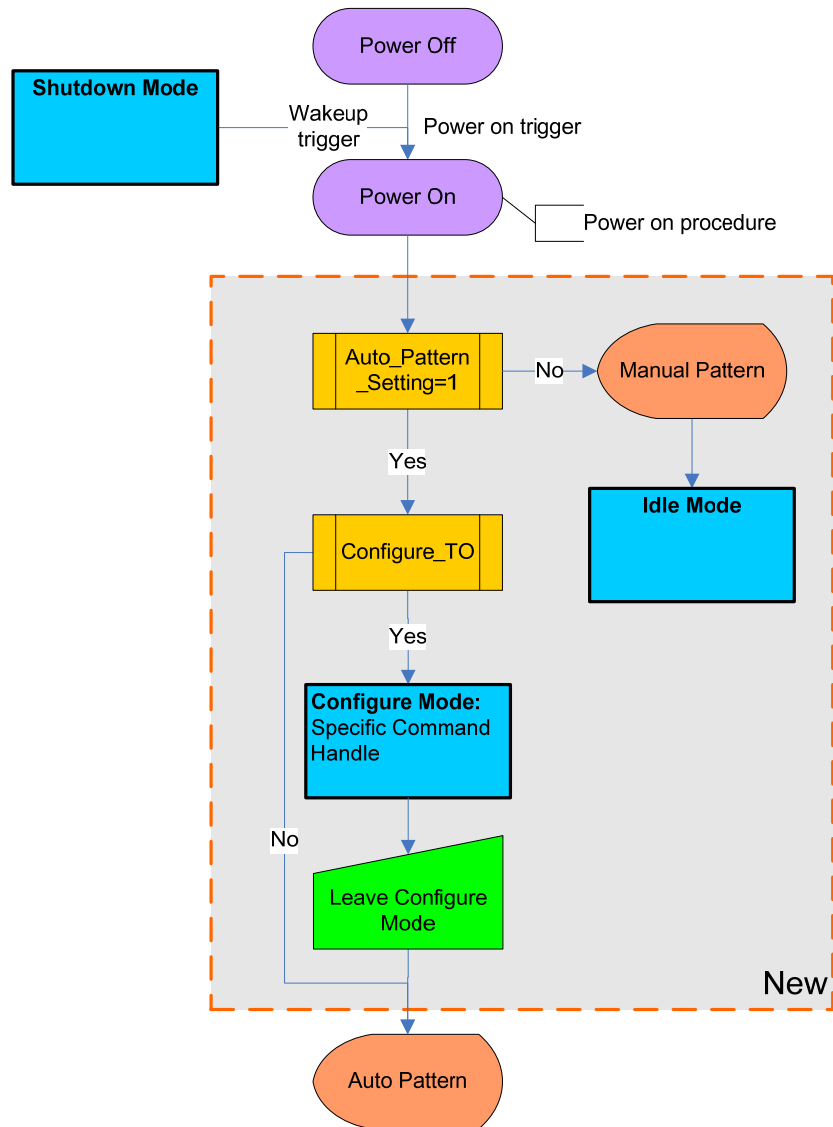

BLEDK3 Command Set

6.2 Auto Pattern

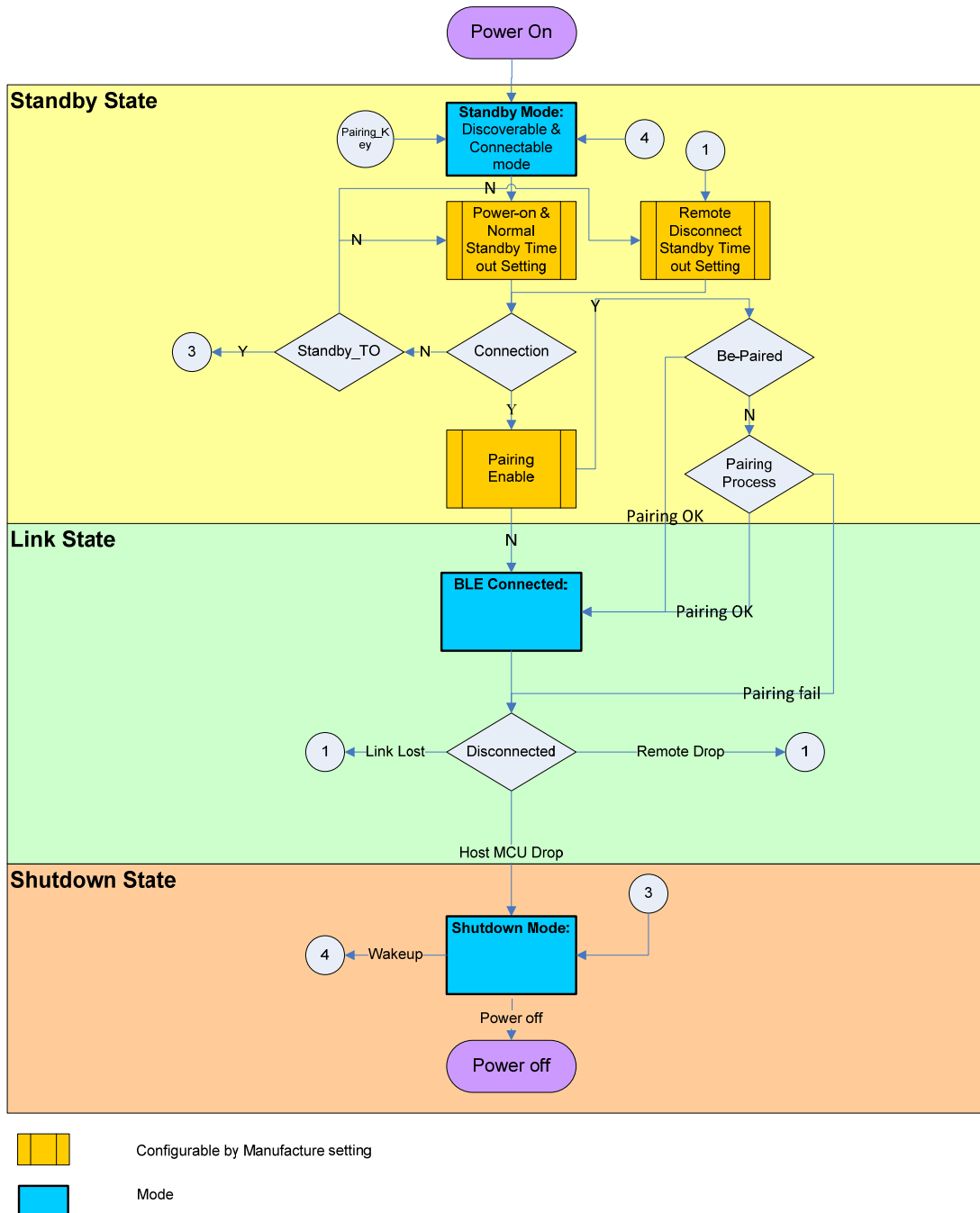

BLEDK3 Command Set

6.3 Manual Pattern

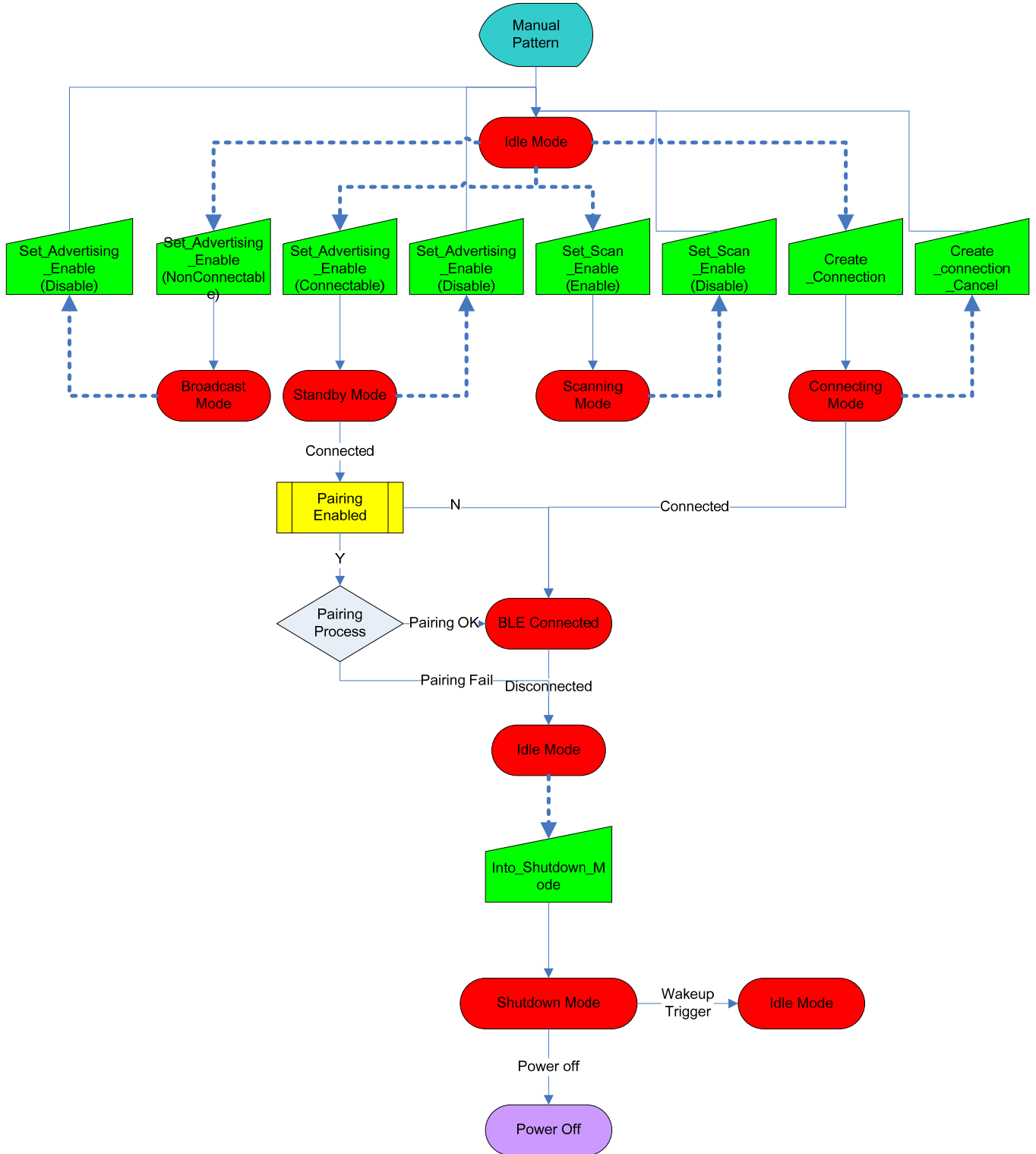

7 MESSAGE SEQUENCE CHARTS

7.1 Standby Mode

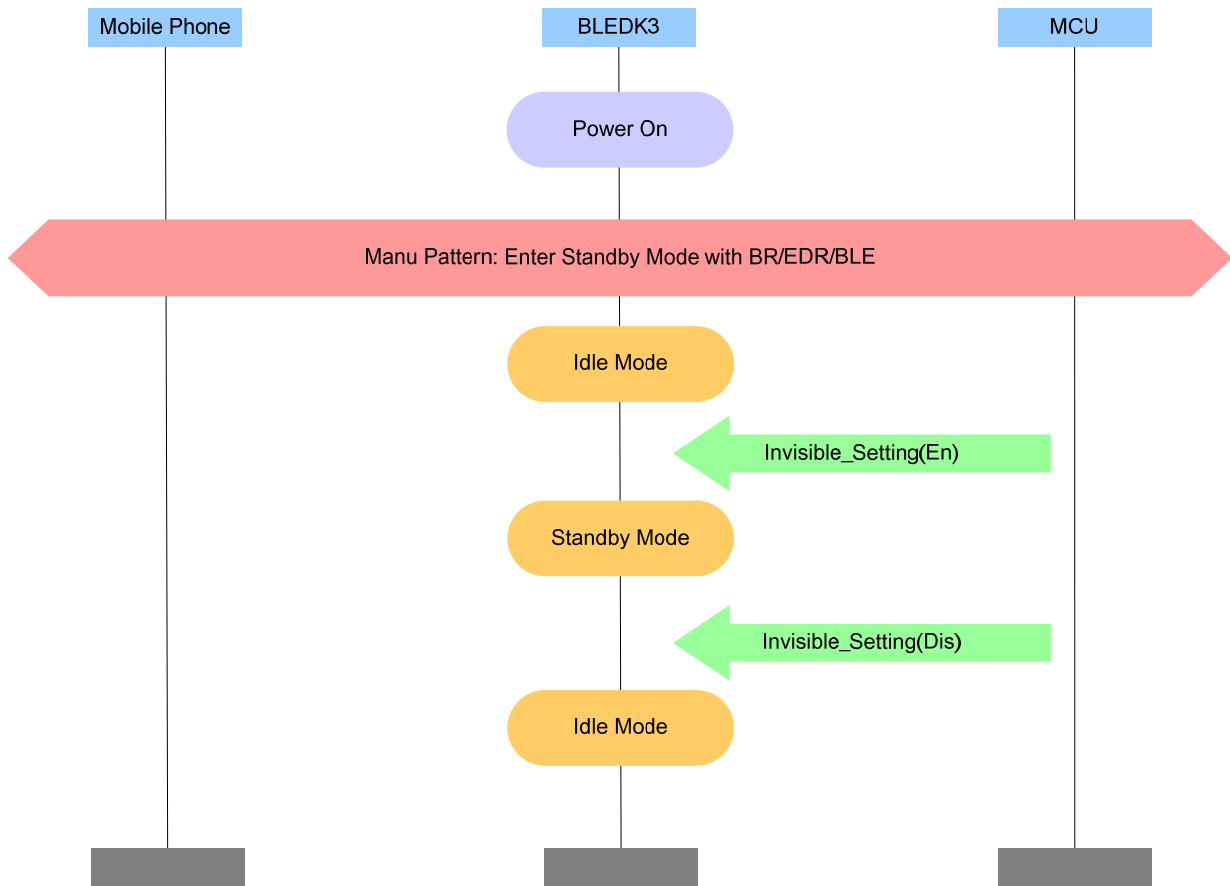

BLEDK3 Command Set

7.2 LE Connected Mode

7.2.1 Manual Pattern Send Data

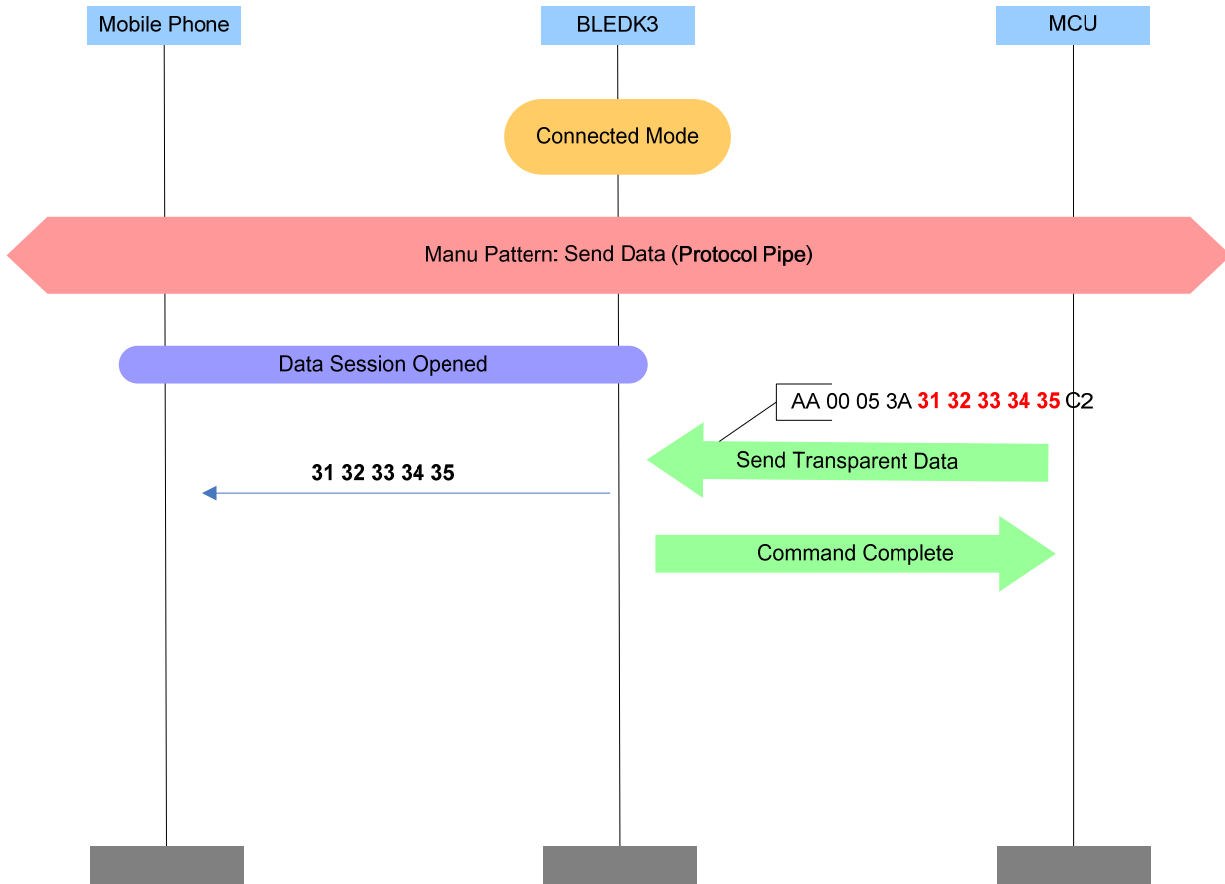

BLEDK3 Command Set

7.2.2 Auto Pattern Send Data

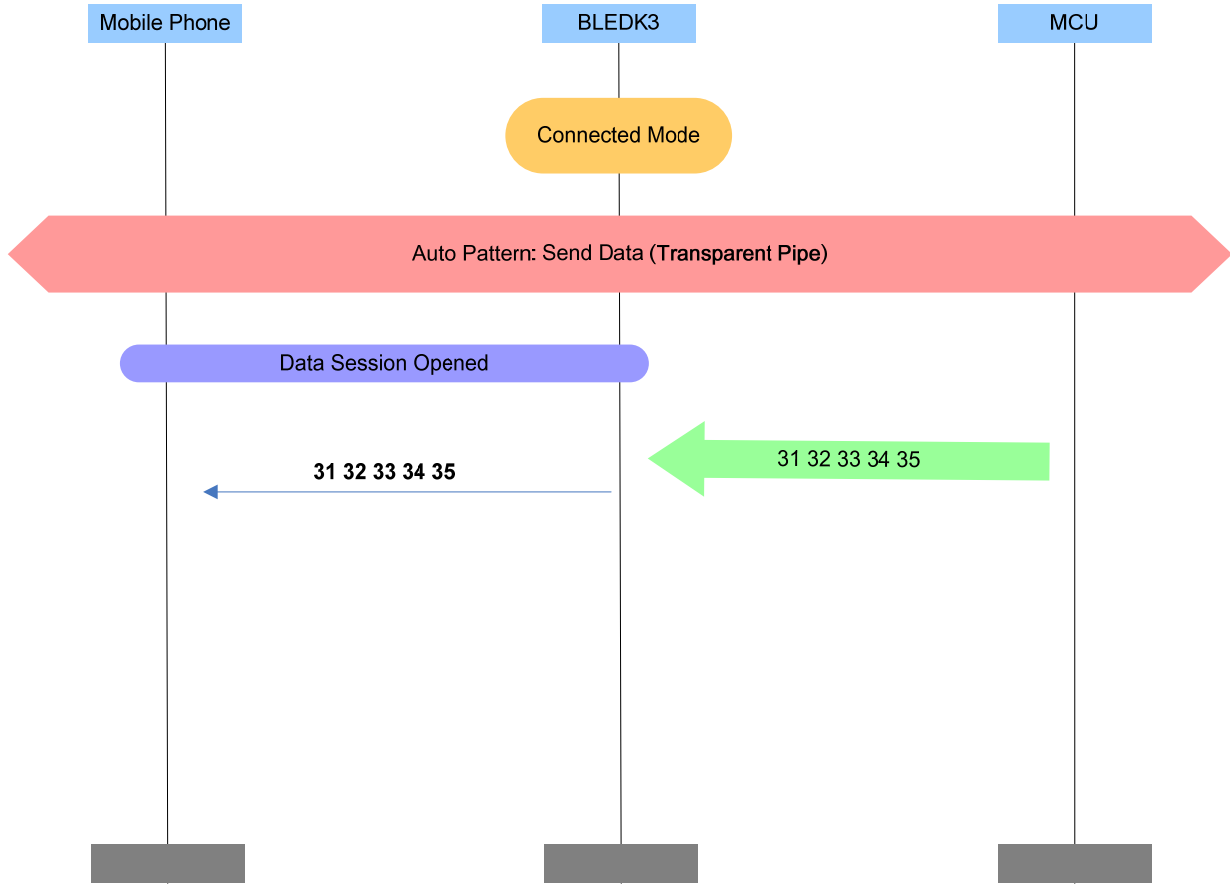

BLEDK3 Command Set

7.2.3 Manual Pattern Receive Data

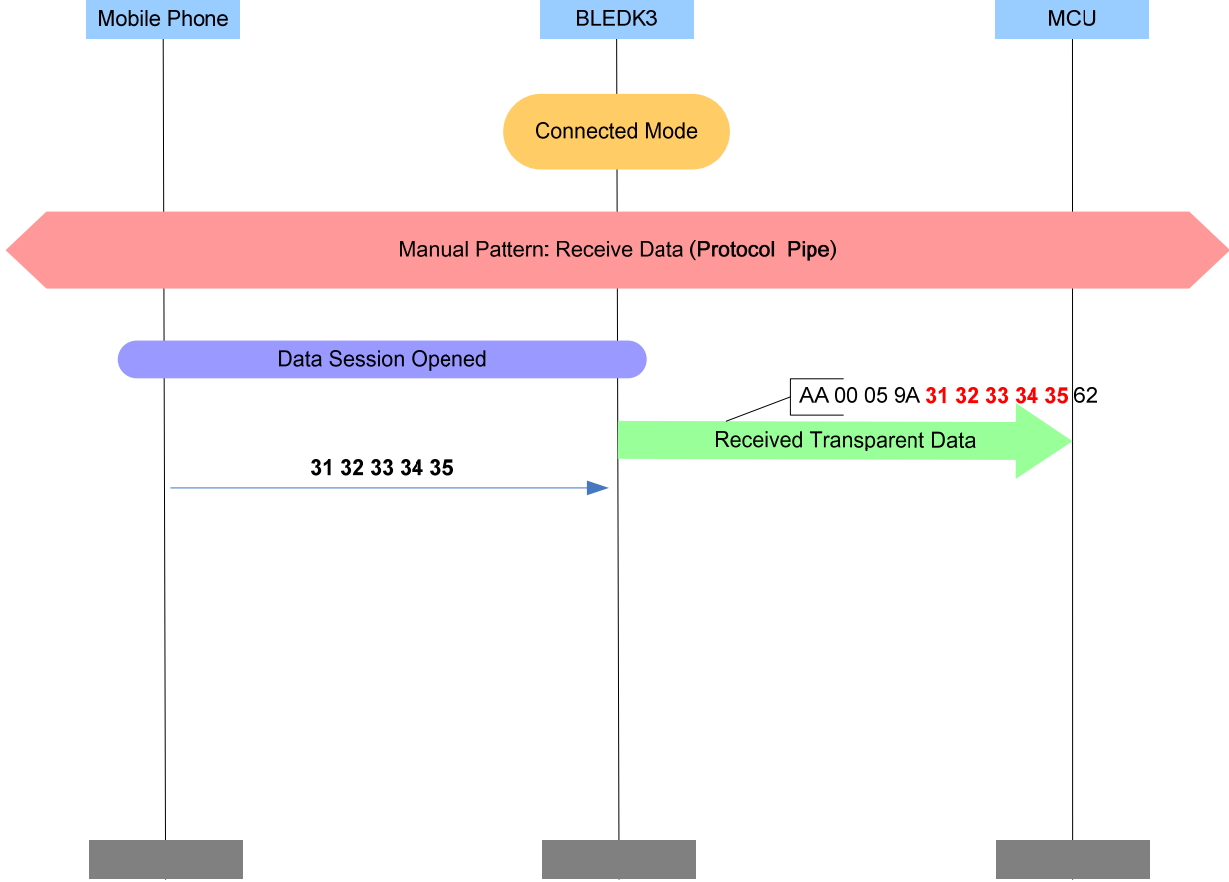

BLEDK3 Command Set

7.2.4 Auto Pattern Receive Data

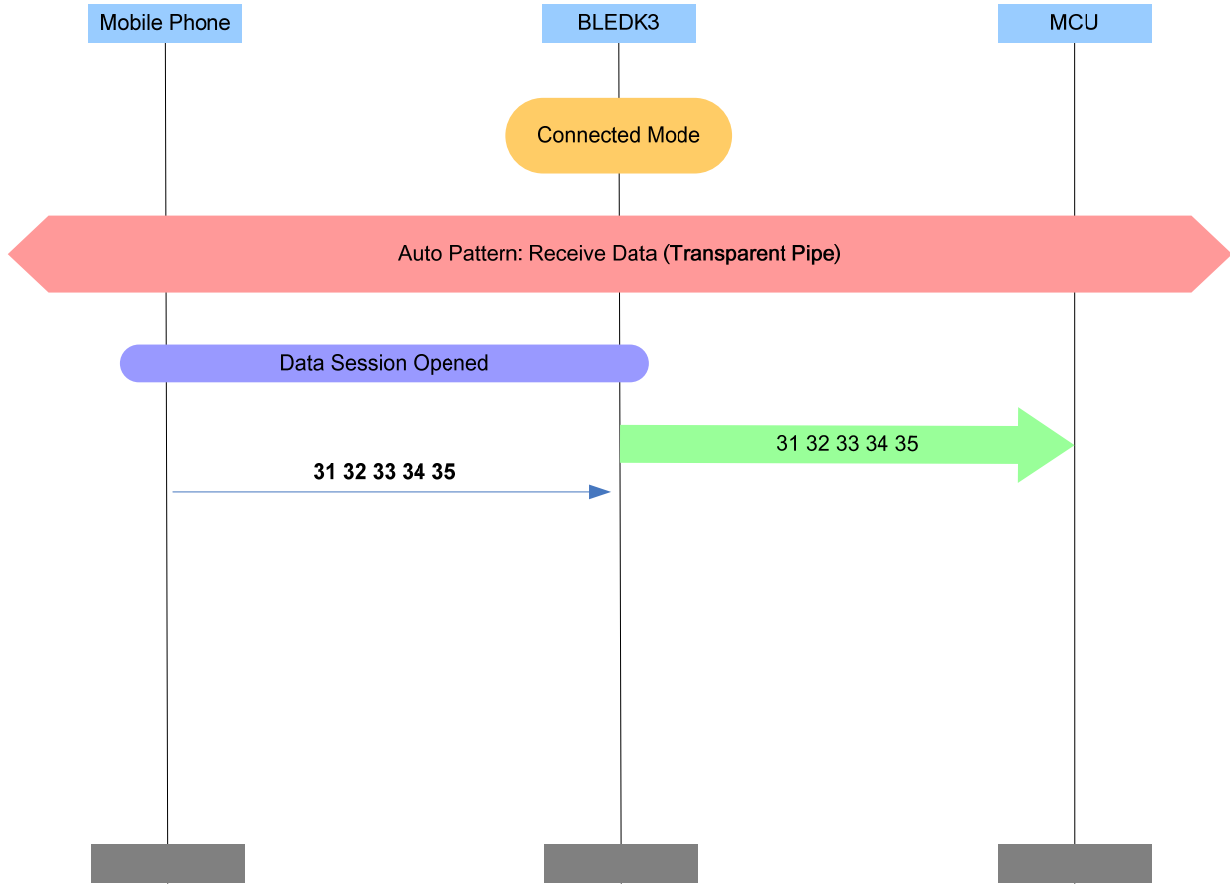

BLEDK3 Command Set

7.3 LE Pairing Method: Passkey Entry

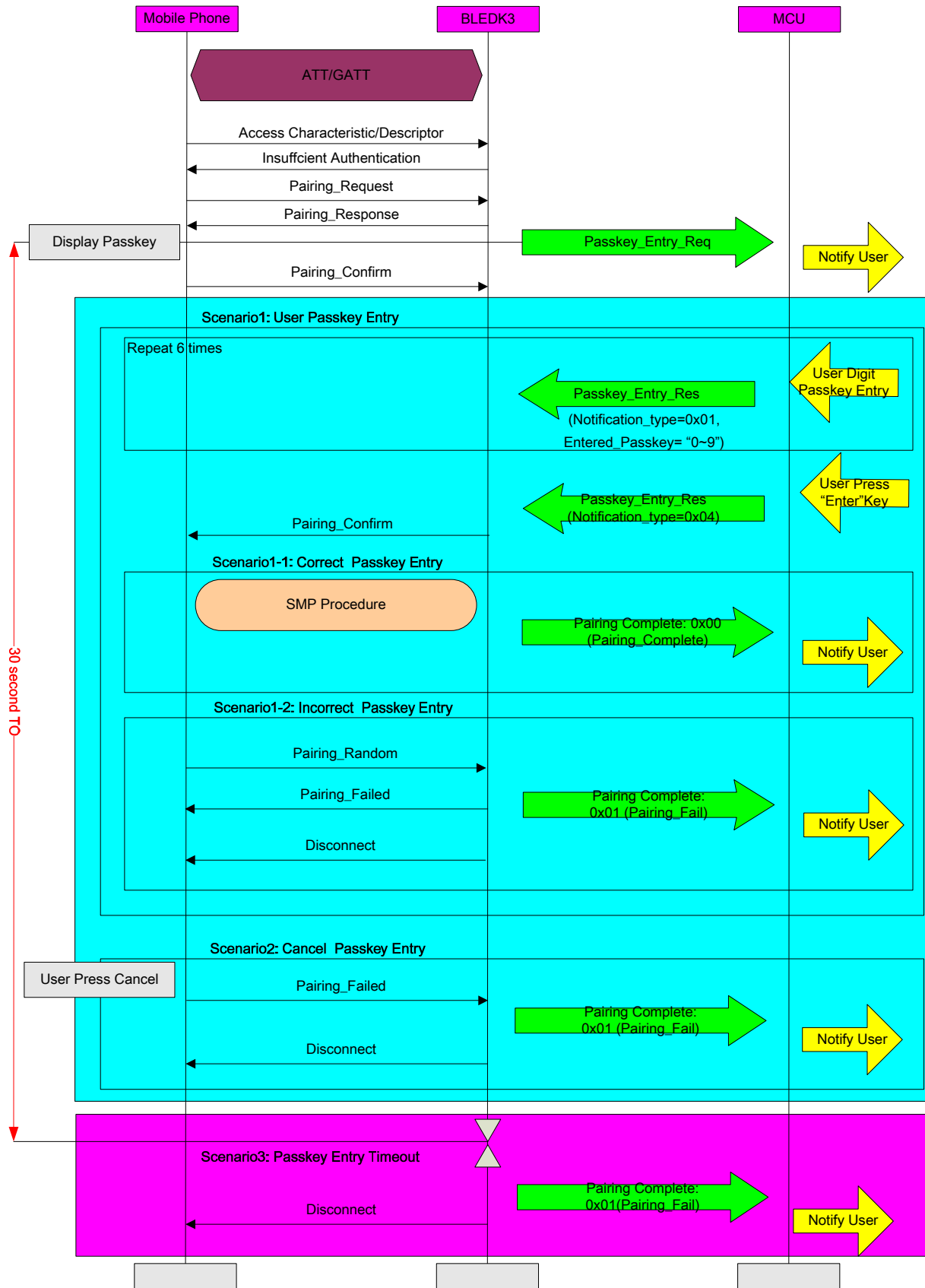

BLEDK3 Command Set

7.4 LE Pairing Method: Passkey Confirm

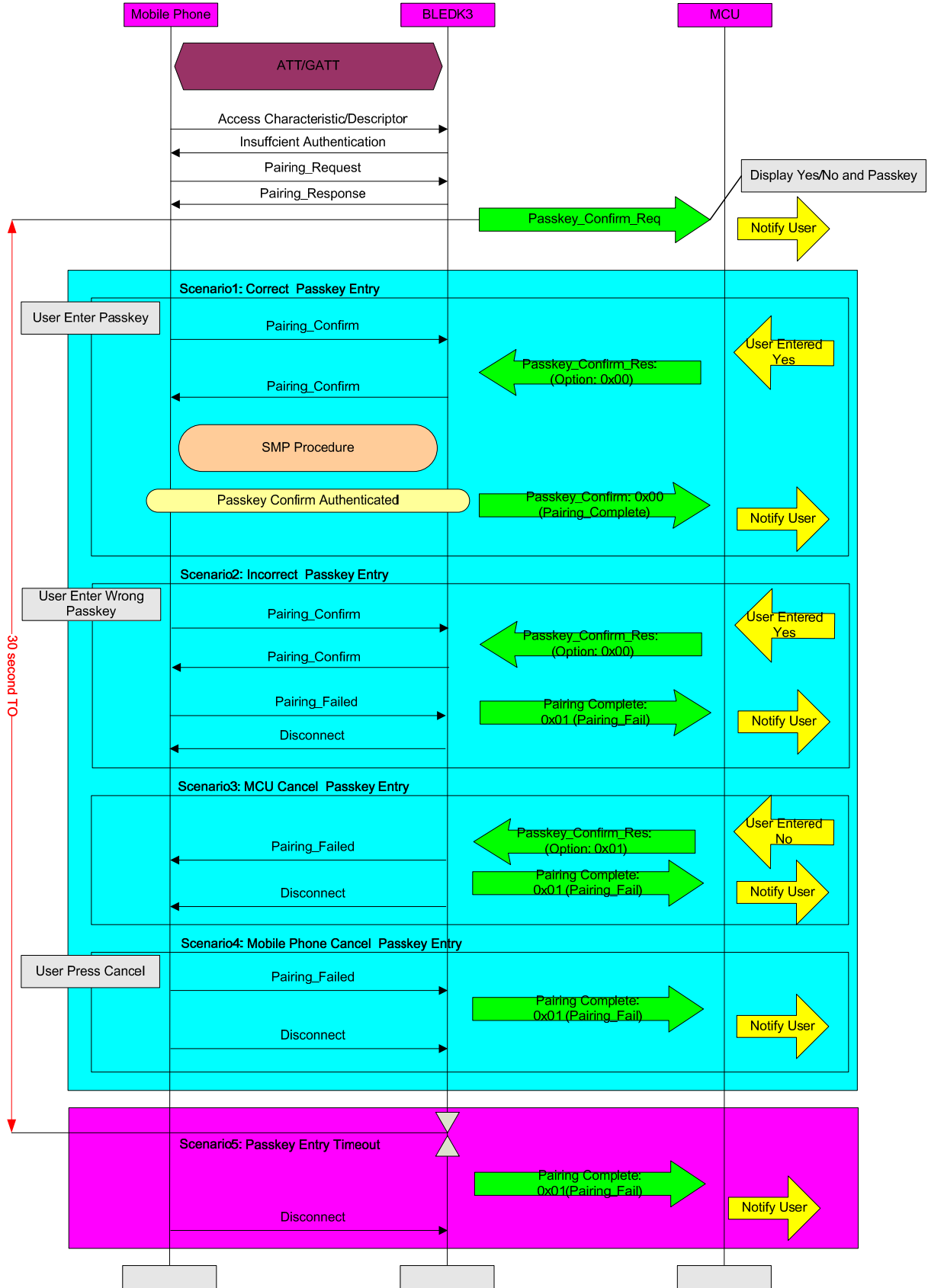

BLEDK3 Command Set

8 LISTING OF COMMAND STATUS ERROR CODE

Error Code	Description
0x00	Command succeeded
0x01	Unknown Command
0x02	Unknown Connection Identifier
0x03	Hardware Failure
0x05	Authentication Failure
0x06	PIN or Key Missing
0x07	Memory Capacity Exceeded
0x08	Connection Timeout
0x09	Connection Limit Exceeded
0x0B	ACL Connection Already Exists
0x0C	Command Disallowed
0x0D	Connection Rejected due to Limited Resources
0x0E	Connection Rejected Due To Security Reasons
0x0F	Connection Rejected due to Unacceptable BD_ADDR
0x10	Connection Accept Timeout Exceeded
0x11	Unsupported Feature or Parameter Value
0x12	Invalid Command Parameters
0x13	Remote User Terminated Connection
0x14	Remote Device Terminated Connection due to Low Resources
0x15	Remote Device Terminated Connection due to Power Off
0x16	Connection Terminated By Local Host
0x18	Pairing Not Allowed
0x1F	Unspecified Error
0x28	Instant Passed
0x29	Pairing With Unit Key Not Supported
0x2F	Insufficient Security
0x39	Connection Rejected due to No Suitable Channel Found
0x3A	Controller Busy
0x3B	Unacceptable Connection Interval
0x3C	Directed Advertising Timeout
0x3D	Connection Terminated due to MIC Failure
0x3E	Connection Failed to be Established
0x81	Invalid Handle
0x82	Read Not Permitted
0x83	Write Not Permitted
0x84	Invalid PDU
0x85	Insufficient Authentication
0x86	Request Not Supported

BLEDK3 Command Set

0x77	Invalid Offset
0x88	Insufficient Authorization
0x89	Prepare Queue Full
0x8A	Attribute Not Found
0x8B	Attribute Not Long
0x8C	Insufficient Encryption Key Size
0x8D	Invalid Attribute Value Length
0x8E	Unlikely Error
0x8F	Insufficient Encryption
0x90	Unsupported Grout Type
0x91	Insufficient Resources
0xF0	Application Defined Error
0xFF	UART_Check_Sum_Error

9 LISTING OF BLEDK3 STATUS

BLEDK3 Status	Description
0x01	Scanning Mode
0x02	Connecting Mode
0x03	Standby Mode
0x05	Broadcast Mode
0x08	Transparent Service Enabled Mode
0x09	Idle Mode
0x0a	Shutdown Mode
0x0b	Configure Mode
0x0c	BLE Connected Mode

10 REVISION HISTORY

Version	Date	History
1.00	2014/10/03	Preliminary Version
1.01	2014/10/06	Modify command parameters <ul style="list-style-type: none"> ● Read_Pairing_Mode_Setting ● Write_Pairing_Mode_Setting ● Write_Adv_Data ● Write_Scan_Res_Data ● Write_Device_Name Modify event parameters <ul style="list-style-type: none"> ● Client_Write_Characteristic_Value
1.02	2014/11/07	Add GATT Server commands <ul style="list-style-type: none"> ● Read_Local_Characteristic_Value ● Read_Local_All_Primary_Service

BLEDK3 Command Set

		<ul style="list-style-type: none"> ● Read_Local_Specific_Primary_Service Modify command parameters
		<ul style="list-style-type: none"> ● Send_Transparent_Data Modify Event Parameters
		<ul style="list-style-type: none"> ● Recieved_Transparent_Data
1.03	2014/11/11	Modify command parameters <ul style="list-style-type: none"> ● Write_Adv_Data
1.04	2014/11/26	Modify command response parameters <ul style="list-style-type: none"> ● Read_Local_Information
1.05	2014/12/01	Modify command format description <ul style="list-style-type: none"> ● DIO_Conrtol
1.06	2014/12/08	Modify UART CTS/RTS pin description <ul style="list-style-type: none"> ● Pin definition
1.07	2014/12/11	Modify command parameters, remove options <ul style="list-style-type: none"> ● Write_Adv_Data
1.08	2015/01/09	Revise state machine charts Revise UART exchange timing diagram
1.09	2015/01/14	Modify command parameters <ul style="list-style-type: none"> ● Read_ADC_Value Add common command <ul style="list-style-type: none"> ● PWM_Control
1.10	2015/01/15	Modify command parameters <ul style="list-style-type: none"> ● Set_Scan_Parameters
1.11	2015/02/26	Add an error code: 0xF0 <ul style="list-style-type: none"> ● Listing of Command Status Error Code
1.12	2015/03/17	Modify BLEDK3 status definitions <ul style="list-style-type: none"> ● Listing of BLEDK3 Status ● Into_Shutdown_Mode Pin definition modified: TX_IND pin <ul style="list-style-type: none"> ● Pin definition UART data flow control diagram modified <ul style="list-style-type: none"> ● UART flow control Modify command name and its functionalities <ul style="list-style-type: none"> ● DIO_Conrtol
1.13	2015/03/31	Change Document Format to MCHP style
1.14	2015/05/11	Add two commands for sending response manually <ul style="list-style-type: none"> ● Send_Write_Response
1.15	2015/06/22	Modify parameters description error <ul style="list-style-type: none"> ● Send_Characteristic_Value
1.16	2015/06/25	Modify parameters length error <ul style="list-style-type: none"> ● Read_RSSI_Value
1.17	2015/09/24	Revise the naming of "Invisible_Setting" to "Visible_Setting"
1.18	2015/10/01	Revise the naming of "Visible_Setting" to "Set_Adv_Enable"

BLEDK3 Command Set

		Add 0x3D command in the command summary table in section 3
1.19	2015/10/29	Revise parameters order for synchronize between projects <ul style="list-style-type: none">● DIO_Control Add one byte information to distinguish HW version <ul style="list-style-type: none">● Read_Local_Information
1.20	2016/02/16	Add one option on PWM channel selection <ul style="list-style-type: none">● PWM_Control Revise command diagrams for command complete timing change <ul style="list-style-type: none">● Erase_All_Paired_Device_Information● Delete_Paired_Device Remove command parameters of unsupported debugging command and revise typing error <ul style="list-style-type: none">● Debug_Command Add suggested command timeout value in section 3.1.